

00 - 8

APEC

:
:

(APEC) 1989

가 가

APEC

가

APEC

APEC

1990

APEC

APEC

가

가

APEC

10

가

APEC

APEC

가

2000

가

2

APEC

APEC

가

가 APEC

APEC

가

APEC

APEC

, APEC

, 1

22

APEC

(Summary Conclusions)

(workplan)

, APEC

APEC

APEC

APEC

가

APEC

,

-
APEC

,
가

- APEC

3.

APEC

가

APEC

APEC

APEC

APEC

가

APEC

APEC

,

APEC

,

APEC

APEC

APEC

가 . 3

4 가 .

APEC 가

APEC

. 1990 APEC

22 가

. 10 5 ()

2000 3 - , ,

APEC , ,

(1990 1994) APEC

가

(1995 1999) 1994

“APEC (Declaration on a Human Resources Development Framework for the Asia Pacific Economic Cooperation)”

1995 11 (Osaka Action Agenda)

가

1994

2000

가

가

5

가 3

2

1

APEC

가

APEC

APEC

APEC

, APEC

가

4.

가

. APEC

APEC

가
APEC
가
APEC
가
APEC
APEC
가
가
(community)
가
가
가
APEC

, APEC

가

10

APEC

, 가

APEC

APEC

,

,

, APEC

,

가

가

가

2 3

가 .

,

.

APEC

가 .

. APEC

,

가

.

.

.

.

,

,

가

- - - 가

가 .

•	1
1.	1
2.	6
•	APEC	9
1.	APEC	9
2.	APEC	17
3.	APEC	22
4.	APEC	30
•	APEC	35
•	APEC	51
1.	APEC	51
2.	APEC	56
3.	APEC	73
•	APEC	79
1.	81
2.	84
3.	가	86

. : APEC91
1. APEC91
2.95
 101

ABSTRACT 103
-----------------	-----------

 113
A. APEC 115
B. APEC 173
C. APEC 377
D. 21495
D. 707

< - 1> APEC	/	11
< - 2> APEC		15
< - 3>	16
< - 4> APEC		20
< - 5> APEC		27
< - 6> APEC	Ecotech	29
< - 7> 2000-2001	APEC	33
< - 8>	APEC	34
< - 1> APEC		36
< - 2> 1		38
< - 3> 2		42
< - 4> 3		..	47
< - 1> APEC		52
< - 2> APEC		58
< - 3>	21	60
< - 1> APEC		79

[- 1] APEC	18
[- 1] APEC	가	89

•

1.

(Asia-Pacific Economic Co-operation, APEC) 9 가
(Human Resource Development Working Group, HRD WG) 1990

21 , , 가 가 , 가

가 APEC 가 .

가 .

가 가

가

APEC

1997 7 3 APEC

“ :

(HRD Challenges and Opportunities for the New Millenium:
Addressing the Impacts of the Regional Financial Crisis)”

, , , ,

APEC

APEC

APEC

가

1)

APEC

(Open Regionalism)

(Consensus)

(non-exclusive),

(non-discriminatory)

, GATT

가 1 GNP가

3 , 300

1)

< >

< 가 >가

"21

" APEC

, 2000 9 < 가 >

, 가 , APEC

D

APEC (Trade and Investment Liberalization and Facilitation, TILF) , , , , , , UR , 14 (Individual Action Plan, IAP) (Collective Action Plan, CAP) 가 가 . TILF APEC (Economic and Technical Cooperation, Ecotech) . Ecotech 6가 가 , 가 가 . 1996 (Subic) “ (A Declaration on an APEC Framework for Strengthening Economic Cooperation and Development)” , , 가 , 6 . , , 1994 2 5 . Ecotech 가 , 가 “ ” 3 APEC (work plan)

APEC
가 .
2000 9
가 “ (Brunei HRD Initiative)” .
, APEC APEC
, .
APEC .
APEC
가 2001 2
. (Ecotech Sub-Committee, ESC)²⁾
APEC .
APEC .
APEC .
. APEC 가
APEC

2) ESC 1996 “ ” 6 가 가
1997 11
(Senior Officials' Meeting, SOM)
SOM
가 . APEC SOM
ESC

APEC
가
APEC
가
APEC
APEC
APEC
APEC
APEC
APEC
APEC
가
APEC
APEC
APEC
APEC
APEC
APEC
APEC
가
APEC
APEC
APEC
APEC
APEC
APEC

가

2.

APEC

가

APEC

,

가

APEC

,³⁾

APEC

,

,

,

APEC

, 1 22

APEC

(Summary Conclusions)

(workplan)

. 1998

APEC

,⁴⁾

APEC

APEC

3)

2000 5

22 APEC

2

APEC

APEC

E-

APEC

가

가

APEC

4) <http://www.apecsec.org.sg/workgroup/hrd.html>

1994 APEC (Annual
 Workplan) APEC APEC
 APEC APEC
 APEC
 5) APEC 가 APEC
 6) APEC
 APEC 가

5) http://www.apecsec.org.sg/apec_organization/policy_procedure/finance/Content.html.
<http://www.apecsec.org.sg/download/hrd/hrdcontents.html>.

6) 2000 7 APEC
 , 9 1
 , 10 < APEC > APEC
 APEC

. APEC

1. APEC

1990
가 , ' 가
(WTO)가 ,
가 .
EU
가 .
가 (offensive liberalization)가
(EU) (,
1995; , 1999). 1980 EU가
" " , 1989
가 . 1980
(EC) , 가 ,
가
EC 1992 ,
, 1993
1 , 11
가 가 .

1989 , , 3
 (NAFTA) . NAFTA 가 가
 ,
 가
 (, 1995).

GATT가
 , 1990
 가 7) APEC
 . (, 1995).
 .
 , APEC -
 . APEC
 . < - 1> APEC 가
 .

1999	57,406	가	APEC
27,563	, 48.0%	,	55,651
26,483	47.6%	,	가

가 1998 APEC ,
 40.1% . 1989
 APEC 가가 , 38.4%, 37.2%

7) 가 , ,
 가
 (, 1999).

< - 1> APEC /

(: US\$)

		APEC	APEC		APEC	APEC
1989	31,380	12,054	38.4%	30,228	11,248	37.2%
1990	35,565	13,010	38.6%	34,250	12,143	35.5%
1991	35,406	13,598	38.4%	34,180	13,237	38.7%
1992	37,950	14,746	38.9%	36,614	14,417	39.4%
1993	37,356	16,103	43.1%	36,520	15,423	42.2%
1994	42,629	18,617	43.7%	41,693	17,581	42.2%
1995	50,678	21,554	42.5%	49,695	20,533	41.3%
1996	53,152	22,906	43.1%	51,728	21,173	40.9%
1997	54,698	23,992	43.9%	53,367	22,630	42.4%
1998	54,647	21,914	40.1%	54,309	22,709	40.1%
1999	57,406	27,562	48.0%	55,651	26,483	47.6%

: UN(1998). *Monthly Bulletin of Statistics*. July.

(1999). APEC 가

(2000). APEC 가

10 가 가 1998 가
 , 1999
 APEC 가
 APEC .
 . APEC
 , 가

1989 APEC

8)

1960

. 1960

(Japan Economic Research Center: JERC)

. JERC

”

5

1967

가,

(Pacific Basin Economic Council: PBEC)가

가

. PBEC

5

17

. PBEC

. 1968

5

(Pacific Trade and Development Conference:

PAFTAD)가

2

가

1970

ASEAN

가 1980 9

가

8)

(1995),

(1999)

APEC

(Pacific Economic Cooperation Council: PECC)가

9) PECC

가

PECC

가

PECC 21

가 (South Pacific Forum)¹⁰⁾

22

가

Task

Force, Fora, Working Group

가

PECC

PECC

가

PECC

9) Pacific Economic Cooperation Conference , 1992 1 Pacific Economic Cooperation Council

10) South Pacific Forum 가 Fed. St of Micronesia, Fiji, Kiribati, Marshall Island, Nauru, Niue, Papua New Guinea, Solomon Island, Tonga, Tuvalu, Vanuatu, Western Samoa .

APEC

APEC

APEC

. APEC

가

가

가

가

APEC

가

가

PECC

1989 11

, , , 6 (, , 가 ,

, , 11) 12 가 APEC

. 1991 3 , , 3

가 , 1993 5 ,

가, 1994 가 가 (< - 2>).

APEC 가

가

가

,

가

3

3

가

가 3

1998

11) ASEAN 1994 7 가 7 .

3 가 APEC 21
 가 가 ASEAN PECC, SPF
 가 .

< - 2> APEC

	가	
1 - (1989. 11.)	, , , 6 (, , , 가 , ,)	12
3 - (1991. 11.)	, ,	15
5 - (1993. 11.)	,	17
6 - (1994. 11.)		18
7 (1998. 11.)	, ,	21

: (1999a).

APEC .

< - 3>

. (PBEC),
 (PECC), . (APEC)

	PBEC	PECC	APEC
	(Pacific Basin Economic Council)	(Pacific Economic Cooperation Council)	(Asia Pacific Economic Cooperation)
	1967 4 ()	1980 9 ()	1989 11 ()
	- 19 가	- 22 2 가 (SPF), - PAFTAD, PBEC	- 21 가 - ASEAN , PECC, SPF
		가	가
		(社)	
	: 5 - - - -	: 1 1 - - -	: 1 - (SOM) : 3 5 - (CTI) - (BAC) - (EC) -

: (1995).

2. APEC

APEC . APEC
 , 가 ,
 가
 (in evolving process) .¹²⁾
 [1] , APEC ,
 , .
 가 ,
 가, ,
 .¹³⁾
 APEC (APEC Economic Leader's Meeting) 가
 , 가 가
 . APEC , , 가
 , 가 .
 ' 가(county)' ' (economy)'
 .¹⁴⁾ (Chinese Taipei) ,
 (Hong Kong, China) .

12) APEC (1999), APEC (<http://www.apecsec.org.sg>) .

13) APEC 가 .
 . 2, 3
 10 , 4
 (Eminent Persons Group: EPG) .
 5 , 6
 , .
 . 1996 APEC
 (APEC Business Advisory Council: ABAC) .
 14) 가 .

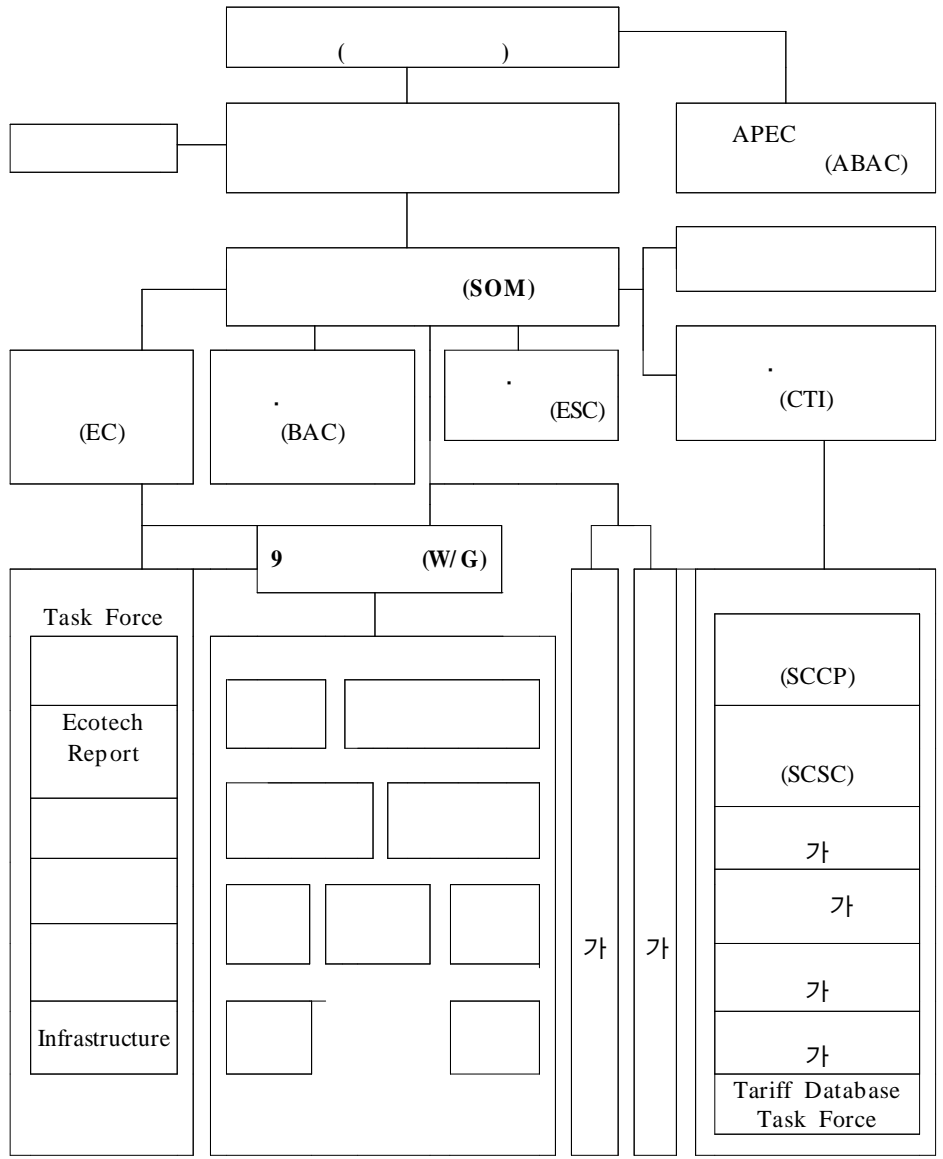

: (1999a) .

[- 1] APEC

“APEC (APEC Economic Leader’s Meeting)”가
APEC , 1993 5
() 1
APEC
가

(Declaration Statement)
APEC 가
(, 1995: 50).

APEC (APEC Ministerial Meeting) APEC
, 가 1
()
APEC
, 가
가 (< - 4>).

1993 1995
, , 9 1 2
가 1

(Senior Officials Meeting, SOM)
3 5
APEC
()

< - 4> APEC

APEC	1993. 11.	,
APEC	1993. 11.	APEC
APEC	1993. 11.	UR
APEC	1993. 11.	.
APEC	1994. 11.	,
APEC	1994. 11.	
APEC	1994. 11.	
APEC	1994. 11.	,
APEC	1995. 11.	가
APEC	1997. 11.	APEC

: (1999).

, , APEC ,

가 . , ,

(Committee on Trade and Investment: CTI) 1993 11

“Declaration on APEC Trade and Investment

Framework” 1994 1 . CTI

APEC

가 . , . .

(Economic Committee: EC) 1994 6

1995 . EC , ,

가 . (Budget Administrative

Committee: BAC) 1993 5

, APEC , .

가

가 . (Ecotech Sub-Committee: ESC) . ESC

1997 11

. . ESC

6 (, , , , , ,

) , SOM .

, SOM .

APEC (APEC Working Group) APEC

,
가 , 10

. 2 ,
 , , , , ,
 , 3 , , 3
 1997 10 .
 가 1997
 (TID W/G) 가 9
 . APEC 가 , APEC
 가
 . APEC
 가 가
 가 (,
 2000).

3. APEC

APEC .
 , , ,
 , 가 .
 .
 APEC 가 (, 1999).
 , APEC .
 가 가 .

(Open Regionalism)

가

.15)

, APEC . APEC

OECD WTO 가

가

, APEC (consensus)

APEC 1 GNP가 3

가 1 GNP가 300

가 , . APEC

가

.16)

15) , (non-discriminatory) (non-exclusive), GATT . 1994 2 EPG() , 1) 가 , 3) , 4) , 2)

APEC (, 1999).

16) APEC 가 APEC 가

APEC 1999 7 11
 , 2000 11 8 APEC
 가 .
 1989 11 가 . 1
 APEC
 . .
 (.
).
 (.).
 가
 (.).
 (.).
 , (.).
 ASEAN, PECC ,
 (.). 가 가
 . 가
 (가).
 APEC .
 . , ,
 .
 가 .
 ,
 APEC .

APEC
 , 4
 (UR)
 , R&D
 APEC
 . APEC

1 (1993 11 ,) APEC
 (APEC Leaders Economic Vision Statement:)
 , (Aisa-Pacific Community)

2 (1994 11) “
 (APEC Economic Leaders’ Declaration of Common Resolve)”
 , APEC
 2010 , 2020

1995

3

(Osaka

Action Agenda)

15

13

4 (1996 11 ,)

(Manila Action Plan for APEC: MAPA)

, Database

6

APEC

5

6

2000

가

가

< - 5> APEC

1 (1989. 11.)	• . 87가	
2 (1990. 11. 가)	•APEC	•7
3 (1991. 11.)	•APEC	•3
4 (1992. 9.)	•APEC	•APEC •APEC •APEC (EPG)
5 1 (1993. 11.)	•APEC • .	• . (CTI) • (CTI) • • • •
6 2 (1994. 11.)	• •APEC	• (EC) • • •
7 3 (1995. 11.)	• : - TILF(15) - ECOTECH(13)	•APEC (ABAC) •APEC • • •
8 4 (1996. 11.)	• (MAPA) •	
9 5 (1997. 11.)	• • •	• •Ecotech
10 6 (1998. 11.)	• •	•BAC BMC ()
11 7 (1999. 9.)		•

: Ahn(1999).

(1999b)

1994

6

APEC

(Declaration on a Human Resources Development Framework for the Asia Pacific Economic Cooperation)

“

” APEC , 가 “

”

가

8

1996

6가

, APEC

< - 6>

Ecotech

, 6

289

가 가

가

,

가

가

79

27%

Ecotech 가

가

. 79

가

33 ,

APEC

< - 6> APEC

Ecotech

					가			
WG	-	-	5	9	9	-	2	25
WG	2	-	-	-	1	1	1	5
HRD WG	33	1	-	2	3	4	-	43
WG	4	-	-	23	20	2	-	49
WG	-	-	-	-	7	-	-	7
WG	9	-	4	11	1	4	-	29
WG	1	-	1	-	2	-	4	8
TID WG 1)	-	-	-	-	-	-	2	2
WG	-	-	-	-	-	4	3	7
WG	5	-	12	2	1	-	-	20
ATC 2)	2	1	-	3	2	1	-	9
CTI	21	3	2	4	-	1	3	34
EC	-	6	5	5	3	-	-	19
SME 3)	2	-	-	-	1	9	-	12
SEOM 4)	-	-	-	-	13	-	-	13
FIN 5)	-	7	-	-	-	-	-	7
	79	18	29	59	63	26	15	289

1): TID WG -

2): ATC - 가

3): SME - 가

4): SEOM -

5): FIN -

: Ahn(1999).

4. APEC

1960 , 1997

가 가

가

APEC

(, 1999).

APEC

1994

APEC

ASEAN 가

가 가

, APEC

'(Open Regionalism) APEC

'(non-discrimination)

1990 EU, NAFTA

WTO .

, APEC .

가 . APEC

, . APEC

, , , , ,

ASEAN, ,

가 .

, APEC .

. APEC .

, ,

가 .

가 .

, APEC .

. ,

EU 8 GATT Round

, (Euro)

EU

. APEC 1994 .

1996 12 가 WTO

(ITA) APEC

,

APEC 가 .

, 1990

가 , APEC
(, 1995: 250).

APEC

APEC

(, 1999). 1991 3
APEC ' ' ,
, , 가 APEC 가
가 . 1992 4

APEC
. 1993 11 5

" . "

, 1993 APEC 가

< - 7> < - 8>

APEC

APEC

, APEC (ABTC)

, ABTC

가 가

. 3 (, ,) ABTC

1997 1 , 1

가 , 1998 , , 1999

가

1998 9 1 APEC , APEC

600 (300) 가

(Asia-Pacific Information Infrastructure, APII)

1994 1996 10
 APII APII

APEC Testbed()

Testbed

APEC 가
 21 1,200 46 4,200
 가,

APEC

APEC , APEC , APEC

< - 7> 2000-2001 APEC

	()	1999. 10.	2000. 12.
	()	2000. 3.	2000. 11.
가	()	2000. 3.	2002. 3.
	()	2000. 6.	2002. 12.
	()	2001. 1.	2002. 12.

APEC	<ul style="list-style-type: none"> • 1992. 12. 5 APEC SOM() 1 • 1993. 11. 5 APEC , APEC
(CTI)	<ul style="list-style-type: none"> • 가
APEC (ABTC)	<ul style="list-style-type: none"> • 1997. 5 1,000 3 ABTC • APEC ABTC 가
(APII)	<ul style="list-style-type: none"> • 1994 APEC • 1995. 5. 1 APEC APII 5 10 • 1996. 10 APII
APEC	<ul style="list-style-type: none"> • 1994. 9. APEC () • 1995. 5. 1 () • 1995. 5. 1 APEC () • 1996. 11. APEC () • 1997. 5. APEC (ABAC) () • 1997. 5. 10 APEC () • 1997. 9. 2 APEC () • 1998. 5. 12 APEC () • 1998. 9. 1 () • 1998. 10. 14 APEC () • 1999. 6. APEC () • 2000. 7. APEC () • 2000. 9. 1 APEC ()

: (1999a).
(1999b).

. APEC

1994 11 APEC
(Declaration on a
Human Resources Development Framework for the Asia Pacific
Economic Cooperation)

(APEC Human Resource Development Ministerial
Meeting) 1 2 APEC
3 , 4 가 2001

APEC 가
, APEC
, 가
3
APEC
3
가 < - 1>
1 18 가 1996 1
1 "21
APEC : (Preparing the APEC Workforce for the 21st
Century: Transition and Challenges)"

< - 1> APEC

<p>1 (1996. 1)</p>		<ul style="list-style-type: none"> ▪ ▪ HRD ▪ 21 - - HRD - HRD 가 가 -
<p>2 (1997. 9)</p>		<ul style="list-style-type: none"> ▪ - ▪ - - (HRD WG) ▪ -
<p>3 (1999. 7)</p>		<ul style="list-style-type: none"> ▪ - - - - (Plan of Action) ▪ 21 - - <p style="text-align: right;">fora가 .</p>
<p>: (1999a).</p>		

“ ” (Joint Ministerial
Statement: Call for Action on Human Resource Development)

가

1 (Osaka Action Agenda)

< - 2 >

5가

APEC

	<ul style="list-style-type: none"> ▪ (Labor Market Information: LMI) ▪ LMI ▪ LMI ▪ LMI ▪ LMI 가 , , APEC LMI ▪ , , LMI ▪
	<ul style="list-style-type: none"> ▪ , , APEC ,
	<ul style="list-style-type: none"> ▪ 가
	<ul style="list-style-type: none"> ▪
	<ul style="list-style-type: none"> ▪

: APEC(1996). [http:// www.apecsec.org.sg/ hrd/ minmta1.html](http://www.apecsec.org.sg/hrd/minmta1.html).

1997 9 2 APEC , 1 .
 “ (The Strategy

for Developing Human Resources under a New Environment and Challenges)”

1

가

APEC

(electronic sourcebook)

APEC

APEC

17)

2

“

(lifelong learning)

(school to work transition)

21

17)

APEC

APEC

APEC

APEC

, 가
가
2
. ,
. ,
. ,
. ,
. / /
. ,
. , ,
. ,

(mentoring)

2

“

”

가

가 21

가

가
APEC
2
“
APEC
가
3가
“
가
1998
APEC
가
가

	<ul style="list-style-type: none">▪▪▪▪ , ,▪
	<ul style="list-style-type: none">▪▪▪▪ , , 가▪▪▪
	<ul style="list-style-type: none">▪ , ,

: APEC(1997). [http:// www.apecsec.org.sg/ hrd/ minmta2.html](http://www.apecsec.org.sg/hrd/minmta2.html).

3 1998 7
1998 가 , , 가
21 . 3 “
:

(HRD Challenges and Opportunities for the New Millenium: Addressing the Impacts of the Regional Financial Crisis)” ,

가

. 3 - :
, : , 21 -

가 ,

3가

가
21

가

(globalization)

1999 APEC

3

가 ,

가,

가

21

가

(individual empowerment)

APEC

“21

”

가

가

가

21

가,

,

21

3가

3

(Plan of Action)

21

,

가

21

,

:

가

/

(

)

(

)

21

1999

가

3

3가

가,

(

(

)

21

가

< - 4 >

APEC

	<ul style="list-style-type: none">•• , 가,• - -• ()•••
	<ul style="list-style-type: none">•••• ,
21	<ul style="list-style-type: none">••••

: APEC(1999). [http:// www.apecsec.org/hrd/minstmt.html](http://www.apecsec.org/hrd/minstmt.html)

, ,

.

가 가

.

, ,

, - ,

,

가 .

,

가

가
가
4가
APEC
APEC 가
APEC
4
2001 9
4

(Human Resources
Development for Both the Advancement of Society and Economy and the
Sharing of Prosperity with People in the Context of Globalization)”
, 2001 4 23

APEC
APEC
APEC
APEC
가
가
가
APEC
APEC

. APEC

1. APEC

APEC 가
. APEC 9 가
(Human Resources Development Working Group: HRD WG)
1989 11 1 () ,
, ,
. 1990 7 2 APEC (가)
,
, 가
APEC 가 가 ,
2000 가 가
22 가 . APEC
< -1>
A .
APEC ,
가

(NEDM: The Economic Development Management Network),
(BMN: Business Management Network),

< - 1> APEC

			가
1		1990. 7. 2 3.	11
2	가	1990. 10. 18 19.	-
3	가	1991. 2. 18 19.	-
4		1991. 7. 11 12.	12
5		1992. 1. 9 10.	14
6		1992. 5. 26 27.	15
7		1993. 1. 26 27.	15
8		1993. 5. 25 26.	13
9		1994. 1. 24 26.	16
10		1994. 6. 13 16.	17
11		1995. 1. 26 27.	17
12		1995. 5. 29 6. 1.	16
13		1996. 1. 21 25.	18
14		1996. 6. 10 13.	17
15		1997. 1. 20 23.	18
16		1997. 5. 26 29.	18
17		1998. 1. 18 22.	18
18		1998. 6. 11 19.	18
19		1999. 1. 26 29.	19
20		1999. 5. 10 14.	17
21		2000. 1. 24 28.	18
22		2000. 5. 27 29.	21

(HURDIT: HRD in Industrial Technology Network) 3 .

1992 8 , (EDFor: Education Forum)

9 APEC (SOM)

APEC 4

. 가 1996 1 1

()

(LMI: Labor Market Information)

4 1

(NEDM)

가 가 . NEDM

(BMN)

가

(executive development

programs), (technical management),

(control system)

BMN

CD-

(HURDIT)

(technologist)

(professional)

(practical skills)

(high

technical knowledge)

(offshore industry)

. HURDIT

(EDFOR)

가 . EDFOR 3가

가

APEC

(LMI)

APEC

1996 11 8

APEC

APEC

LMI LMI

, APEC

3가

APEC

가

3가

가

가

,18)

가

,19)

가

18) 1996 11

3

(the APEC Center for Technology Exchange and Training for SMEs, ACTETSME)

19) 1995

가

가

가 .
(Lifelong Learning Coordinating Committee)가 .
가 10
APEC ,
1999 3 가
. 2000 1 22 5
3 - , ,
- , 20)
(Education Network, EDNET)
, , . .
가 .
(Capacity Building Network, CBN)
, ,
, , / APEC
(Labor and
Social Protection Network, LSP)
, , ,
, .
APEC APEC
. 3
2
, 1989 2000 APEC (APEC Joint Ministerial
Statement), 1993 2000 APEC (APEC Leader's Declaration)
. .
. 1994 11 ()

20) , EDNET , LSP . CBN

APEC
APEC
APEC
2
)
3
(1995 11) APEC
‘(Action Agenda)’ 가
‘HRD (Joint Activities for HRD)’
21
. 1996 1 1 가 , 4
(1996 11) APEC ‘ 6
1990 80
가
가

APEC Partnership for Education(), Vocational Training Program
(), APEC Education Foundation()

2. APEC

1990 7 APEC
1 (1990 1994), 2 (1995 1999), 3
(2000)

가. (1990 1994)

APEC

가

3

1

(SOM)

가

가

가

가 가

APEC

가

1993

(PECC, Pacific Economic Cooperation Council)

(1995 1999)

1994

“APEC

(Declaration on a Human Resources Development Framework for the Asia Pacific Economic Cooperation)” 1995 11 (Osaka Action Agenda)

“APEC

”

< - 2>, < - 3>

, APEC

(APEC Leaders’ Education Initiative)

. APEC

APEC

(APEC National Study Center)

, APEC

APEC

, APEC

(APEC Business Volunteer Program)

가

< - 2> APEC

4가	1. . 2. , , 가 3. / , / 4.
8가	1. 2. 3. , , , 4. , 5. , 6. , 7. , , , , 8.

<p>APEC 8</p>	<ol style="list-style-type: none"> 1. 2. 3. 4. 가 5. 6. 7. 8. 9. 10. 11. 12. 13. 14.
<p>APEC</p>	<ol style="list-style-type: none"> 15. APEC 16. APEC 17. 18. APEC 19. 20. 가 21. APEC

가 , 가 , 가 .

가 .

가 .

가 .

가 .

가 .

1996 1 1 가
5가
. 5가 , ,
, , ,
5

가
,
가

1997 1 15 가
8

- 1.
- 2.
3. , 가,
가
4. , , ,

5. , , , 21 ,

6.

7. , , ,

8.

8가

(TILF)

(annual workplan)

가,

1999

APEC

IMF

1999

(ECOTECH)

· (2000)

2000 가 가 .

5 가 3 .

(EDNET, Education Network), (CBN, Capacity Building Network), (LSP, Labor and Social Protection Network)가

1 가

2000

가 APEC APEC

2000 APEC 가

가 . ' 가 (Brunei HRD Initiative)' ,

가 APEC

가 APEC .

가

가 .

1)

21 , , ,

가 21

가

2000 . 가 . ,
가 가
가 「APEC
: 21 (Human Capacity Building: Meeting the
Needs of the 21st Century)」

21 .

가 . ,

가 가
가 가 .

가 가
가 가 .

가 가 .

APEC 가

1. APEC

2. APEC

3. APEC

APEC 1993

42%가

2 3 APEC

3 1

APEC

1993

60%

1999-2000

3 APEC

4

APEC

(ESC)가

가

가
APEC
APEC
APEC
(SOM)
APEC

1. APEC
(Human Capacity Building Report)

가

2. APEC

3. 가

4.

5.

APEC
2001
가
가
가
가
APEC
가

가

APEC

APEC

가

가

가

(distance learning)

가

(e-commerce)

APEC

가 가

APEC

가

가

APEC

가

(World Bank),

(ADB)

가

APEC

ADB

APEC

가

가

가

APEC

가

가

21 APEC

2) 2000 11

APEC

2000 11 13

APEC

(

HRD

)

APEC

가

(SOM)

APEC

가

가

2001 6

가

2001 9

APEC

APEC

(Ministerial Meeting)

()

1 1

APEC

가

가

가 2001

가 6
 9 . 2000 11 25
 가 가
 가 가
 가 가
 가 , , , ,
 가 ,
 가
 APEC
 2001
 APEC , 가
 , APEC 가
 21 .
 가
 가 APEC 2010
 APEC
 가 ,
 . 2001

APEC

2001 APEC
가

(APRU, Association of Pacific Rim
Universities)

가 가 :

1. .

2. 2001 .

3. ,

4. APEC .

5. APEC .

6. .

1992 5

6

, 4 , 5 , 6 , 1 , 3 가

6

가

가

(KOICA)

APEC

, 3

(KAIST)

2

KAIST

1993 7

,

,

10

1993 5 8

, 1994

1 9

9

가

10

10

10

가

가

1998

2000 4 22

8

(NEDM)

KDI가,

(BMD)

, (HURDIT) 가 . 가
 3
 , NEDM() BMD() 가 1
 가
 8 HURDIT 'APEC
 1994 APEC
 1994 1 9 가 . 8
 (annual
 workplan) 가
 1994 9
 가 .
 가
 2000 9
 1 APEC
 10 .
 가
 17 가 APEC
 (NEDM) (KDI
) 가 1995 5
 12 . 12 (EDFOR) '
 APEC

1996 1 가 . 가 APEC
 13 가
 APEC
 가 . APEC
 2001
 APEC
 1997
 1997 HRD
 1996 6 14 1997
 1997 1 15
 8
 1997 5 16
 1998 1
 17 1997 9 23-26
 2 APEC
 APEC
 APEC
 1998 6 18

'APEC , 'APEC
, 'APEC ' 3

1999 1 19

1999 5 20 20
KDI 가 APEC

2000 1 21 5
3 (CBN,
Capacity Building Network)
(LSP, Labor and Social Protection Network)
(EDNET, Education Network)
LSP CBN
CBN
(Restructuring Task Force) 가 APEC
APEC
2000 APEC
(e-education)

가 가 .
'APEC ' APEC

2000 4 22 1 APEC
가 2000 9 22-25 ,
가 .

가

22 가 2 6

1 APEC

2000 3 APEC APEC
APEC

. APEC

APEC APEC
 가 .
 APEC .
 "APEC (APEC Project Guidance)"²¹⁾ 2000 8
 4 .
 APEC , , , TILF(.
) , 1 1 12 31
 . APEC APEC ,
 , . APEC
 APEC . APEC TILF

APEC .

< - 1> APEC

가, APEC) (TILF APEC	4/ 5
-----------------------------	------

()

21) C .

< - 1> APEC ()

가, ,	4/ 5
(Chair/ Lead Shepherd) APEC	6 *
(MS Word 6.0)	
APEC , BMC BMC (BMC 가)	BMC APEC () 7/ 8 .*
SOM BMC가 APEC	9 *
SOM	11 *
APEC	1
	1
TILF APEC , APEC TILF (BMC 가 , 1)	4/ 5
/ 가 , 가	
	2 (HRD , 2000 05/ 2000 2001 12 31)

: * BMC
 , APEC http:// www.apecsec.org.sg/
 가 ,
 BMC APEC

: APEC(2000).

APEC , , <
 -1> . 11
 APEC
 APEC 200
 가 3 7 ,
 3 .

1.

APEC 4 5
 APEC APEC , 4 5
 가 .
 APEC , APEC 6
 . 7 8 BMC(.
) 9 .
 BMC가
 , 11 ,
 1 APEC
 1
 APEC APEC
 가 (self-funding) .
 APEC ,
 APEC 15%
 . 2001 200

, APEC 2001 7 BMC 2002
3 . 15%
TILF .

가

BMC 2 3 7 8 2
, 7/8 . ,
2/3 .

, APEC

, BMC가 7/8

가

. BMC 2

, ' '

BMC

가

(C Annex A).

가

A4 10

/

가

가

. 가

, TILF 가 APEC 가
 가 APEC
 가
 가
 TILF 가 Ecotech 1999 9
 (Ecotech) 가 (Weightings Matrix)
 가
 APEC BMC
 BMC
 BMC
 APEC 가
 "APEC 가 "(C Annex B
) 가 APEC
 가 TILF
 "TILF : 가 (C Annex C
)" . 2000 7 BMC
 TILF
 가 가
 1 15

BMC

2.

가 APEC
, APEC

APEC

, 가
APEC

. APEC
(C Annex E). APEC
APEC

APEC

APEC

APEC

APEC

(Directors)

가

가

APEC

가

가

APEC

5 . BMC

BMC

BMC 가

APEC

BMC

가

, BMC

가

, APEC

가 BMC

가 가

가

, BMC

3 1 4 3

가 , 6

가,

3. 가

가 APEC
, 가
, 가 (CTI)
APEC
가 (가 C Annex F3
) 가 가
BMC
, , CD
, 5 (hard copy) (electronic copy)
2 가 APEC
BMC APEC
가 7 (small group) BMC
APEC 가
BMC BMC
가 (, ,)
BMC BMC
BMC BMC
(, ,)
) BMC SOM
, BMC

가 ,

가 4가 , APEC 가 ,

APEC 가 APEC 가

SOM , BMC

. APEC 가 ,

APEC 가 /

APEC 가

가

Ecotech

'1996 Ecotech '(1996

Manila Declaration on Ecotech) 6

APEC

가

22)

가

가

9가

22) C Annex B1 , 1998 6 SOM APEC
 Ecotech (Guidance on Strengthening Management
 of APEC Ecotech Activities)

(associated output),

APEC
APEC

가

가
가

가 (a) (:

), (b) (, /), (c)

APEC

가

가 APEC
가 SOM 가

가

APEC

가

[- 1]

가 , 가 , 가 ,
가

가 가
.

2 가
, , 가 , ()
.

가 4
, 가 ,
.

가 2 ,
가 , APEC
BMC .

[- 1] APEC 가

APEC .
APEC APEC
APEC . 2000 3 APEC
"APEC 가 " . 2000 6
22 EDNET
() , 가 가 APEC

2002 APEC

. : APEC

1. APEC

APEC ,
가
가
APEC (ecotech)
(SOM)
가
APEC 9
가
가
APEC
APEC

1999 2000 APEC 4

3 , APEC

APEC APEC 가 가

APEC APEC

가 가

APEC 가

APEC 가 , APEC 가가

21 APEC 가

, APEC

가

가
가

가

가

가

가

, (,),
(community)

가

가

가

. 가 APEC

가

, 1990

가

, , ,

, 가,
가

가

, 가
가

가

, 가

APEC

가

가 가

. APEC

가

가

가

가

가

APEC

1990

가

1990

가

가

가

가

APEC

21

가

가

가

APEC

가

가

가

가

가

가

2 3

가

APEC

가 .

가 APEC

가

가

APEC

가

가

가 가

APEC

가

APEC

가

가

가

- - - 가

가

가 가 , 가
가
가 ,
가
가
2001 APEC
APEC
가 APEC
가 APEC
,

- (1999). **3 APEC**
- (2000). **21 APEC HRD**
- (1999). **APEC WTO**
- : (KOPEC)
- (1999a). **1999 APEC.**
- (1999b). **1999 (APEC)**
- (1995). **APEC**
- (2000). "APEC
" 『 』, 3 5 (10).
- (1999). **APEC 가**
- (2000). **APEC 가**

- Ahn, Hyungdo(1999). *APEC After 10years: Is APEC Sustainable?*, Seoul:
Korea Institute for International Economic Policy.
- APEC(1996). Meeting of APEC Human Resource Development Ministers
(Manila, Jan 11, 1996).
(<http://www.apecsec.org.sg/hrd/minmta1.html>)
- APEC(1997). 2nd Meeting of APEC Human Resource Development Ministers
(Seoul, Korea, Sept 26, 1997).
(<http://www.apecsec.org.sg/hrd/minmta2.html>)
- APEC(1999). Third APEC Human Resource Development Ministers Meeting
(Washington, D.C., United States, July 28-29, 1999).
(<http://www.apecsec.org.sg/hrd/minstmt.html>)
- APEC(2000). *APEC Project Guidance*, 4th edit.
- UN(1998). *Monthly Bulletin of Statistics*, July.

ABSTRACT

**Current Status of
APEC Human Resource Development Working Group
and Its Significance for the Korean Case**

Korea Research Institute for Vocational Education & Training

Research-in-Charge: Lee, Jeong Taik

Research Staff: Lee, Young-Hyun

Shin, Ik-Hyun

Baik, Sung-Jun

Kang, Il-Gyu

Park, Tae-Joune

Lee, Dong Im

Lee, Eui-Kyoo

Lee, Jeong-Pyo

Cho, Eun-Sang

Cho, Jeong-Yoon

Ko, Hye-Won

Hong, Sun-Yee

1. Research Summary

This research project is focused on the HRDWG (Human Resource

Development Working Group), one of the nine Working Groups existing in APEC (Asia-Pacific Economic Cooperation), since 1990. It will explore in various areas the present situation the human resource development is in, and its significance for Korea's human resource development.

HRD is acknowledged as one of the key areas where partnership projects are taking place, and is being progressed in wide spectrum within APEC but in Korea systematic and analytical research has still not been accomplished. Moreover, with the establishment of Deputy Prime Minister of Education · Human Resource Development around the corner, the understanding of APEC organization and HRDWG and its project trends is ever more important but still lacks any systematic summary of existing reference materials for further understanding.

Therefore this research paper will outline human resource development related activities in APEC and significance of them for Korea's human resource development. Furthermore, it will suggest policies that could enhance APEC HRDWG to play a more active role and those that could help facilitate Korea to participate in the APEC HRDWG activities.

2. Research Methodology

To explore the APEC HRDWG's activities and present situations, this research paper investigated documents, participated advisory meetings, and had consultations to collect and analyze the research materials to provide with adequate policies. APEC Ministerial Meetings joint-statements, action plans, directives, summary conclusions of past

APEC HRDWG meetings, other APEC fora meetings, and specialists in APEC HRD arena in Korea, were all resources to accomplish this research. The following is the references used for this research.

As the first step, research related to APEC, and resources published from the Ministry of Foreign Affairs and Trade, Ministry of Labour, and Ministry of Education were all used as reference materials. Secondly, APEC HRDWG related resources such as all of the past 22 HRDWG meeting summary conclusions and workplans were utilized. Thirdly, project directives and management regulations published from the APEC Secretariat and APEC HRDWG were analyzed.

Next, both formal and informal meetings with APEC Secretariat personnel and people who participated in APEC conferences were consulted. Also government officials in charge of APEC international cooperation in Ministry of Foreign Affairs and Trade, Ministry of Labor, and Ministry of Education were inquired for APEC HRD's prospects and intentions.

3. Research Content

This research focuses to grasp the overall picture of APEC HRD, and the route APEC HRD projects took to be developed, and at the same time tries to upgrade APEC HRD's understanding in Korea. Assisting the Korean Government establish an adequate policy for Korea's active human resource development is also another purpose for this research.

In chapter 2, the outline of APEC is displayed to help better understand APEC organization as a whole. It explains how the economic cooperation between Asia-Pacific countries had taken place during the pre-APEC era, and how these activities became the background for the establishment of APEC. In addition, APEC's organizational features, current major projects and Korea's participation in APEC, are all briefly elaborated in the outline.

In chapter 3, APEC HRD Ministerial Meeting's activities were examined. HRD Ministerial Meetings have such significance that it provides the directions and the principle's for APEC HRDWG activities. There were up to three Ministerial meetings and the fourth will be taking place in Japan in 2001. APEC HRD Ministers' have continuously emphasized policies on the expansion of labour market analysis, extension of Small and Medium Enterprises (SME) role, work-education linkage, and the pursuit of human resources development through participation among the public, private, and labour-management.

In chapter 4, APEC HRDWG's activities were introduced and its chief concerned issues and trends were analyzed. APEC HRDWG which was established in 1990, is known to be the most active working group within APEC. In the beginning, it consisted of five networks; Network for Economic Development (NEDM), Business Management Network (BMN), Industrial Technology Network (HURDIT), Education Forum (EdFor), and Labour Market Information (LMI), but from year 2000 it was restructured into three networks for more efficiency in operation, which is the Education Network (EDNET), Capacity Building Network (CBN), and the Labour and Social Protection Network (LSP).

APEC HRDWG activities can be examined in three phases: period of formation, project progression, and structural reforms. In 1990 to 1994 it can be seen as the formation period where APEC HRDWG economies focused on discussion of selection of the target areas and implementation for cooperation activities needed for member economies' human resource development. During this period HRDWG concentrated on partnership projects that could enhance economic development and policy formulation, business management, and industrial technology for future human resource development.

The second phase, project progression period (1995-1999) was initiated with a direction and framework set up when the '94 Jakarta Ministerial Meeting adopted "Declaration on a Human Resources Development Framework for the Asia Pacific Economic Cooperation" and the Leaders' and Ministers' Meeting approved the Nov. '95 Osaka Action Agenda. With the Declaration Framework and Osaka Action Agenda, HRDWG established concrete project objectives and policies to implement the principles. From '94, Annual Workplans were also composed to monitor projects more efficiently.

In the third phase which is the structural reformation period, HRDWG underwent structural and organizational reformation. This change is not yet completed and still in process. The biggest change was the restructuring of the networks from five to three, and the curtailment of the number of annual meeting from two to one. In addition, it highlighted the need for human resource development to be dealt not only in working groups but in the whole of APEC and noted importance

of the participation of private enterprises and non-government organizations as crucial for future prospects.

Korea's APEC HRD participation is portrayed in various areas such as meeting participation, joint projects, sponsoring working group meetings and seminars, and nomination as the network coordinators and the Lead Shepherd.

In chapter five, the research paper introduces the procedure and the process projects take in order to be endorsed. First, the selection process the joint-projects have to undergo, and the procedure of endorsement project proposals go through for APEC fund use, was reviewed.

4. Policy Suggestions

Policy suggestions were mainly made in two directions. To explore ways that would enhance APEC HRDWG's cooperative projects and the significance of APEC HRDWG activities in Korea.

As the first step, cooperative programs HRDWG should further undertake is proposed in the following paragraphs.

Firstly, APEC HRDWG should find ways how private sectors and non-governmental organizations can actively take part in. Private sectors' involvement means that market mechanism is secured in the process. Applying market mechanism presupposes market competitiveness and efficiency in investment. However, APEC tends to regard democracy over

efficiency since APEC has the objective of promoting development of all member economies equally at all times based on consensus for any actions to take place. In this context, APEC HRDWG should find ways to overcome and compromise the contradiction inherent in the dual principle of efficiency and democracy.

Secondly, imposing market principle in APEC for private sector enhancement, would cause a new problem because it would damage each member economies cultural identity. It is important that APEC HRD preserves both the cultural attributes of each economy and simultaneously maximize individual economy's capacity building. APEC's strategies for enhancement of capacity building at the cost of deprivation of cultural identity if any, should not be contrived as projects or goals which can obtain continuous participation or cooperation by the Asian economies where cultures are their important resources.

Thirdly, the human resource development strategy that HRDWG has to pursue should be based on diversity. In this light, the Government, private sectors including companies and universities, vocational training institutes, and special international organizations should be interlinked together into a community. This is to lead the participation of private sectors as well as increase the sense of community.

Fourth, rectification of only few developed economies taking the initiative for partnership projects and the rest of other member economies following them should be made. In order for this change to come true, atmosphere where all member economies have an equal voice to state their opinion should be created. Of course, for developed economies to

achieve their goals, they have resources such as capacity to persuasiveness, mobilization of member economy's support, and information power. But since APEC is inclined towards the ultimate objective of creating a community of economic cooperation, there is a need for developing member economies to foster their ability for project proposals.

Fifth, the most important aspect in advancing the APEC HRD and project proposals is to continuously improve projects that are currently in progress by strengthening project assessments rather than to restructure organizations in terms of reciprocal coordination. Over the past years, there were many projects that were initiated that ended with only seminars and summary conclusions. It is important that more efficient project implementation take place.

On the other hand, the APEC HRDWG activities suggest the following significance to Korea.

First, it is recommended that Korea participate more actively in Leader's Meetings, Ministerial Meetings, SOM (Senior Officials Meetings), and Working Group Meetings. In Korea for the past years, Ministerial Meetings, SOM, and Leader's Meeting were mainly prepared for by the Ministry of Foreign Affairs and Trade, and other related Ministerial Meetings and Working Group Meetings were prepared for by the relevant Ministeries. But during this preparation process, wide variety of participation and ideas from people is recommended and as APEC encourages participation of private sectors, so should Korea deal with this issue. Therefore, the Government should open the opportunity for

special agencies such as the businesses, universities, vocational training institutions, and other research institutions.

Second, active participation in the level of Working Groups is advisable. There was a tendency for Korean delegations take interest in areas where they were only interested in. But in the near future, Korea should act accordingly to its status in Asia-Pacific region and heed interest to other member countries activities, and at the same time consider HRDWG's prospects and partnership projects. People participating in the conferences should be proficient in English and have substantial understanding on the issues being discussed with experiences in meetings. It will also be difficult for the meeting to have a fruitful outcome if the membership of participants changed all the time. Last of all, it is important for the HRDWG meetings to not just end as a formality but to have several working group meetings to prepare for specifically and concretely.

Third, participation of KRIVET (Korea Research Institute for Vocational Education and Training) is crucial for active participation of Korea in APEC HRDWG. KRIVET could act as the backbone for Korea's research on the APEC HRD and promote its relations. Korea is at the stage where the Government should newly establish HRD strategies. There should be more exchanges and interactions among APEC member countries to obtain experiences, and it is preferable that the KRIVET play a leading role. Therefore we should seek a way for KRIVET employees to participate in the annual Working Group Meetings. Moreover KRIVET could play a prime role in Asia-Pacific region as the standard qualification developer. Therefore collaborating with Japan, China, and,

Singapore, in education, training, qualification, and evaluation in a long-term perspective step-by-step, and then finally gaining support from the HRDWG would be beneficial in approaching the standard qualification system.

A. APEC

B. APEC

C. APEC

D. 21

E.

A

APEC

(Summary Conclusions)

APEC
2000 22
APEC
APEC
APEC 가
1990 1
(Summary Conclusions)
. 18
,
. 2
가 가 .

5.

- 1) 7 6 , 가
- 2) APEC , , ,
- 3) APEC
- 4) .
- 5) APEC APEC
- 6) '91-'92 .
HRD
- 7) PECC APEC 가
PECC가
- 8) , ,
가 2 HRD WG
- 9) KDI

3 APEC

1.

: 가
: 1991 2 18-19
가 가:
:

2.

3.

4.

- 가
(HRD)
- 가
R&D
- 7

5.

1)
2) APEC 가

- 3) 가 (- , -) 2-3 .
- 4) HRD HRD : PECC .
 HRD PECC
 HRD Pacific Economic Cooperation
 Council(PECC) 가 APEC
 PECC
- 5) : WG
- 6) : APEC HRD WG
- 7) : 1
 APEC HRD
 가 .

4 APEC

1.

: ()
: 1991 7 11-12
가 가: , _____ , , , , , ,
 , , 가 , , (12 가)
:

2.

가 , APEC . , PECC
HRD HRD .

3.

: 가 (lead Institution)
 , . . ,
 .
APEC : 가 ,
 .
:

4.

- 13 APEC ,

- PECC 가

-
-
HRD WG

5.

1) 가

2) (formulation seminar)
APEC 가

3)

4) 가

5) WG 가 , WG , WG

6) , WG

5 APEC

1.

: ()
: 1992 1 9-10
가 가: , , , _____, , , , ,
, , , 가 , _____, , (14
가)
:

2.

, , APEC
(HRD)

3.

: (NEDM) ,
 . (BMN)
(HURDIT) .
-APEC . : .
: , PECC-HRD ,

4.

- NEDM
 .

- HRD ,
, APEC , APEC
가, , 3

5.

1) APEC-HRD-BMN 가

2)

3) 가

HURDIT

4) '92

5) APEC-HRD ,

가 가 , 가 가
, APEC-HRD WG

6) APEC PECC

7)

APEC : APEC HRD WG
APEC
(UMAP): ,

4.

- HRD WG , 가
- WG ,

5.

- 1) HRD WG HRD ,
- 2) HRD APEC , WG
- 3) UMAP 가

- (SOM)
 - (BMN) APEC
 \$10,000

5.

- 1) PECC HRD APEC
- 2) UMAP 가
- 3) WG APEC
- 4) APEC HRD ILO
 PECC
- 5) APEC WG WG
- 6) WG
- 7) HRD
 , 'APEC-HRD 가

- , , ,
- APEC WG

5.

- 1) BMN ,
- 2) HURDIT , HRD,
HRD
- 3) .
- 4) .
- 5) 가,
, HRD
- 6) APEC : (BMN),
APEC (HURDIT), APEC
(NEDM), (BMN),
(BMN),
HRD (HURDIT)

PECC HRD : PECC FDI
 가
 APEC : , , WG
 , APEC , WG
 : 3 . SOM
 WG

4.

- HURDIT APEC
- APEC
- APEC
- APEC APEC

5.

- 1) BMN 가 ()
 , HURDIT 12
 , NEDM WG
 가
- 2) WG
- 3) SME WG

-APEC 21 2
50
(UMAP) 가
APEC : 11 HRD WG
PECC-HRD : PECC가
SME
APEC :
APEC :
18
50
APEC : APEC , APEC ,
Fulbright ,
APEC : APEC

4.

- (), ,
, ,
- BMN , NEDM HURDIT 11
HRD WG , 1-1
- HRD WG ,
- BMN HURDIT가

- APEC : APEC SME , APEC

5.

1) APEC SME가 SME

2)

3) SOM HRD WG APEC WG ,
1 2 , 가가

11 APEC

1.

: ()
: 1995 1 26-27
가 가: , , , _____, , , , , ,
, , , , _____, , , ,
, (17 가)
:

2.

, HRD 가 , ,
, SME . APEC

3.

HRD 가 : HRD
APEC APEC , ,
WG .
: NEDM NEDM , , SME
, HRD . BMN
,
16 . HURDIT
,
가 ,
(EDFOR): 12 4 .

: HRD
 . SME
 APEC SME
 HRD WG APEC (PBEC,
 PECC, APBNet...)
 APEC : 'APEC HRD'
 APEC ,
 APEC HRD
 HRD APEC : , APEC
 SME , SME ,
 -APEC , -APEC
 ,
 , APEC , APEC
 , PECC-HRD

4.

- HURDIT ,
 가 .
 - ,
 , APEC .

5.

- 1) 6 ' '
- HRD WG APEC .
- 2) . / ,

3) 1 , .

, APEC

, PECC-HRD

PECC-HRD : HRD

NEDM PECC가

1996 APEC

- : 1. (HURDIT) 2. HRD
- (BMN) 3. APEC (NEDM) 4.
- (EDFOR) 5. HRD :
- (NEDM) 6. (BMN)
- 7. SME (HURDIT) 8.
- (EDFOR) 9.
- (BMN) 10. H.R.(BMN) 11.
- / (NEDM) 12.
- (BMN)

3.

- 1) APEC 가 .
- 2) 13 HRD WG
- 3) HRD WG 2 1 5/6 .

(BMN):

APEC fora

(HURDIT):

APEC

:

'97

'94 APEC

가

APEC

(BVP):

BVP

가

'95 2 SOM

SME

(): Bogor

BMN

APEC SME

SME HRD

가

APEC SME

APEC

APEC (): *APEC*, *HRD*, *APEC*
APEC
 , 가 ,
 .
 2/3
 .
 , , ,
 .
 (*PFP*): *APEC* *PFP*
 .
 .
 : (), *UMAP* (), *APEC*
 (), *PECC HRD* (*PECC*)
APEC HRD HRD : *HRD*
 .
 ,
 , *APEC*
fora .
 .
 .
 가
 : *BMN* , *NEDM*
PECC fora ,
 , *HURDIT APEC*

APEC fora : APEC
APEC fora
: 5 . . . 가 .

3.

1) *HRD WG*

PECC-HRD : APEC . HRD WG

APEC : APEC HRD , SOM I SOM II,
APEC , *G-Book*,
APEC . APEC fora
가
, APEC

HRD : (LMI)
. APEC

APEC HRD , 가

WG ,

: NEDM APEC LMI . BMN 17
HURDIT HRD , SME,

: 8
HRD ,

: SME ,

HRD

: APEC

SOM

APEC :

(UMAP): APEC UMAP
. UMAP

APEC :

-APEC

(JAPET): 가
().

APEC :

8

().

APEC SME

(ACTETSME): ACTETSME
APEC

APEC :

().

APEC LMI : LMI

SME :

, APEC SME

SME

APEC

: APEC 14 가

4

1

APEC

(BVP): APEC BVP

BMN :

5

:

. HRD WG

HURDIT : SME

NEDM :

(LMIG): LMIG

LMI

LMI가

SME : SME HRD WG
SME

: HRD WG APEC
fora

: 5 HRD,

10가

. HRD WG
가 가

BMN : BMN

. NEDM

가

SME

. BMN

16

5

가

: BMN

가

가

(EdFor): EdFor

NEDM

:

, , HRD

SME

: SME

가가

HURDIT

:

가

(LMI): TILF

APEC

HRD

:

: HRD WG

HRD WG

: HRD BMN

가

2 HRD (): ' HRD WG 1.

- ' ' , 2.

, 3.

, 4. . . ,

5.

(...)

- ' ' 1.

, 2. . , 3. .

- ' ' , 가 . .

.

- . APEC

HRD APEC . APEC fora: APEC fora

HRD APEC

, APEC , APEC SME . APEC

HRD IT .

HRD

APEC : 6 가 APEC 6

(CHRO) , ,

HRD , APEC

, : APEC
 , APEC
 .
 WG
 APEC
 . '96 HRD WG 81.82%
 .
 : 가 8가
 APEC . .
 .
 BMN : BMN 5가 HRD WG
 . 가
 .
 (IQAS) (SCSC)
 .
 (EdFor): ,
 ,
 .
 EdFor .
 .
 (LMI): LMI ,
 , ,
 . APEC LMI
 .
 APEC
 .
 NEDM : ,
 , .

APEC HRD WG

. NEDM APEC

HURDIT : 8가 APEC .

. 8 5

HURDIT

, HRD

SME

: WG

WG : HRD WG

. SME

APEC fora

SME, 가 ,

'97

, WG , 가

가 . , WG 5

5 BAC

HRD WG

. WG

'98

:

HRD

APEC

,

,

8가

. HRD WG

'98 APEC

HRD WG

ISTWG

: APEC

NEDM

, , ,

BAC

NEDM

4

,

BMN : , 가 APEC
가
(BVP),
가 .

(EdFor):

HURDIT : 5가 . .

(LMI): ,

가

가

가

가

HRD WG

NEDM : . .

HRD WG

APEC

. HRD WG , , ,
 , , (NGO) .
 : APEC HRD
 가 .
 .
 : HRD WG
 . HRD WG
 . HRD WG APEC
 .
 HRD WG
 . APEC IFI()가
 .
 NGO
 HRD WG : APEC ,
 , APEC ,
 : HRD WG
 . WG ,
 . NEDM
 , SME ,
 가 , HRD WG
 ,
 LSAC .
 가 : HRD

. LMI

(EdFor):

가

HURDIT

: 3

HRD

APEC

World

Bank, ADB, ILO가

(LMI): LMI

, LMI

가

APEC

:

APEC

가

NEDM

. APEC

가

3

:

가

3

: '97

WG가

APEC

HRD

(. .),

가

: *SME*

SME

WG,

WG

.. *APEC*

BMN :

(EdFor): 2 *APEC*

'21

가

HURDIT :

(LMI):

. LMI

NEDM

. LMI
NEDM : HRD WG
. 2001
(가)
. APEC
. 3 APEC HRD
.
,
.
: . ECOTECH
HRD-ECOTECH

APEC , APEC , APEC BVP .
 BMN : SME BMN , WG
 (EdFor): HRD WG 3 , EdFor
 EDNET ,
 7 가 .
 HURDIT : ,
 가
 , ,
 가 .
 : 5 , 3
 (LMI): APEC 가
 NEDM : , ,
 (TDM).
 :
 , HRD

(CBN):

(EDNET): EDNET

(LSP):

WG

: 'APEC 2000

HRD

HRD

가

. APEC

B

APEC

(Annual Workplan)

B APEC 1994
(Annual Workpan) . 가
(1994 , 1995 , 2000) APEC
(1997 , 1998 , 1999) . 1996 가 .

APEC

1994

- 1.0
- 1.1
- 1.2

- 2.0 APEC HRD
- 2.1 APEC HRD
- 2.2 APEC HRD
- 2.3 APEC HRD
- 2.3.1 (SOM)
- 2.4 APEC HRD
- 2.5 APEC HRD
- 2.5.1
- 2.5.2 - HRD
- 2.5.3 - HRD

- 3.0
- 3.1
- 3.2
- 3.3 APEC HRD
- 3.3.1
- 3.3.1.1 (Co-ordinators)
- 3.3.2
- 3.3.3 가
- 3.4 HRD

- 4.0

4.1	
4.1.1	
4.1.2	
4.1.3	(theme)
4.1.4	
4.1.5	APEC Working Group
4.1.6	
4.1.7	
4.1.8	
4.2	, , Working Group
4.2.1	
4.2.2	
5.0	APEC
5.1	
5.2	APEC HRD
6.0	

APEC HRD

1.0

1.1

APEC 1993 5 8 HRD 가 ,
가 9
1994 1
가 APEC

1.2

2 3

2.0 APEC HRD

2.1 APEC HRD

1991 11 APEC

.
; APEC -
;
가 ,
;
; 가 ,
; 가 가 ,
.
가 ,
가 ;
(economic dynamism)
가 ;
가 ,
.
(consensus)
가 ;

2.2 APEC HRD

1993 11 APEC

APEC

(policy dialogue)

APEC

(labour mobility)

, APEC

APEC

(APEC Business

Volunteer Program)

(human resource development)

2.3

APEC HRD

1993

11

17

19

APEC

APEC

(industrial restructuring),

'APEC

(Senior Officials)

HRD

가

2.3.1

(SOM)

APEC

11

14

16

HRD

50

가

HRD

HRD

(Eminent Person

Group)

2.4 APEC HRD

APEC (APEC-HRD)

APEC

HRD

가

(work force)

HRD

(primary),

(secondary),

가

2.5 APEC HRD

HRD 가
. HRD (resource
intensive)
(multilateral agencies)
(duplicate) , HRD
APEC

APEC

가

2.5.1

HRD

1. 가
- 2.
- 3.
- 4.
- 5.

6.

7. HRD

8. 가 (growth incorporating economic)

2.5.2 - HRD

, HRD

1.

2.

3. (exchanges) (gaps)

4.

2.5.3 - HRD

()

;

()

;

() HRD ;

() 가

;

() ;

() ;

(Business Management)

PECC

HRD
가 가

APEC

3.0

3.1

APEC

APEC
가

, APEC
17
가

3.2

8 HRD , APEC , 가가

9

3.3 APEC HRD

, 가 APEC HRD 가 4

3.3.1

가 APEC HRD APEC HRD (Business Management Network) (Human Resource Development for Industrial Technology), (Economic Development Management) 4 HRD

HRD 가 , 가

3.3.1.1 (Co-ordinators)

(NEDM), (BMN) (HURDIT) 2
3 . 8
. 9

3.3.2

1992 APEC
APEC
HRD 2 7 8
9
HRD HRD
HRD
. 8 HRD "
APEC

3.3.3 가

3.3.4

3.4 HRD

APEC HRD

APEC
가

HRD
. HRD

. HRD

4.0

4.1

4.1.1

2 , 1 5
1

1

가

가 . 3가

가

4.1.2

가

가

가

APEC

가

4.1.3

(theme)

가 가

APEC

APEC

HRD

(theme)

;

()

HRD

()

HRD

() HRD 가

() (Labour Mobility)

() HRD (Regional Standards)

() (Capacity-Building in Managerial Education)

() HRD

() HRD

()

가

4.14

가

9

가

(SME)

4.1.5 APEC

8 , APEC APEC APEC

4.1.6

1993 11 , 가 , APEC
(3.1
) 가 ,
(Pacific Economic Cooperation Council)
가 PECC HRD
PECC

6 ,
APEC HRD

4.1.7

, APEC
가

“

APEC

APEC

”

(4.2) (Business Management Network)
(Human Resource Development for
Industrial Technology)

4.1.8

APEC HRD 가

(Host governments of co-ordinating institutions pay for costs associated
with establishing the day-to-day management of networks.)

7 , APEC Central Fund

;

a) APEC

b)

c)

APEC

4.2

APEC

(1992)	0
(1993)	\$217.500
(1992)	0
(1993 9 30)	0
(1994)	\$238.825

4.2.1

()

()

4.2.2

5.0 APEC

5.1

, 200 US 가 1994 APEC
, 1993 가 1994

5.2 APEC

APEC HRD

APEC (US) 4.2 APEC
APEC HRD .

6.0

1
 , 가 , HRD
 , APEC HRD . 1
 ,
 9 , 가 HRD
 APEC
 ,
 , 2 3 .

APEC

1995

APEC

1994 11 11 12 6 ,
· ,
, APEC
· APEC (HRD-WG) APEC
·
HRD APEC , ,
·
·
, APEC
,
, 가
· , APEC
·
·
APEC HRD
1. 가
,
·

2. , , 가
3. , .
4. , .
1. ;
2. , , ;
3. , 가 ;
4. , - ;
5. APEC , .

.
 , 가 / /
 .
 (more
 and better) . “ (more and
 better)” HRD
 . “ (more and better)”
 , (international
 mobility) 가 , SME 가
 , APEC ,
 .
 APEC 7가 4가
 ;
 1. , 가 /
 ;
 2. , ;
 3. , 가
 ;
 4. .

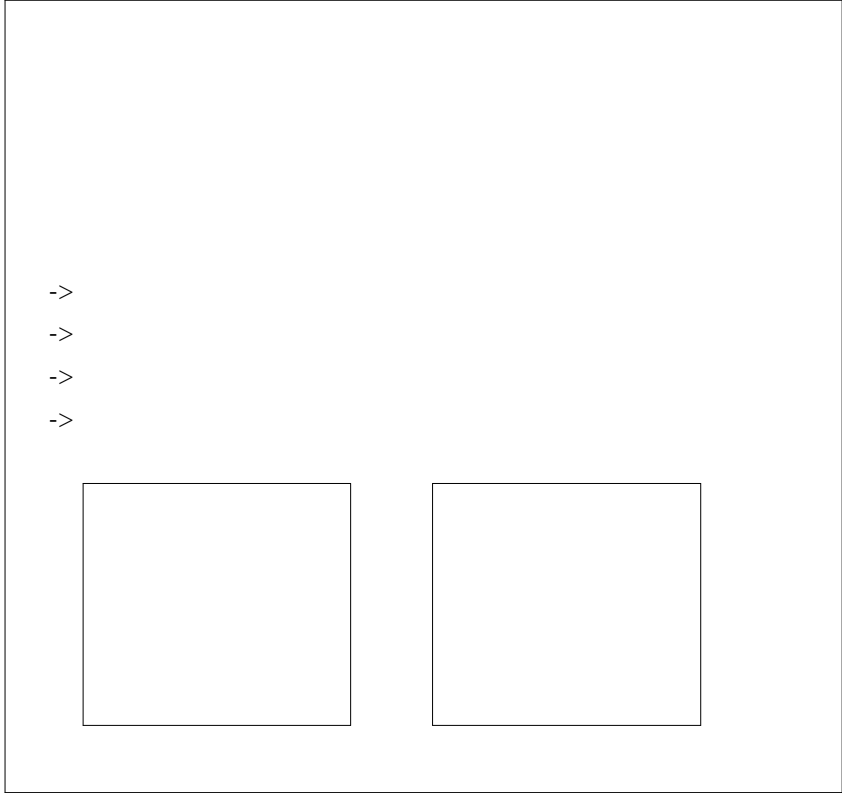

1.

APEC

APEC

가

a.

1995 1996

1.

(EDFOR);

b.

1995 1996

. APEC (EDFOR);

. APEC 2 (EDFOR);

. (EDFOR).

c. , APEC

1995 1996

. APEC (EDFOR).

2.

APEC

APEC 3 (tripartite resources) (Pacific
Economic Cooperation Council)

1995 1996 :

- a. (development) ;
- b. (outlook);
- c. ;
- d. 1996 .

가 NEDM PECC ,
NEDM가 HURDIT . 가 .

3.
, 가 / 가
.

가 , APEC

BMN , 가 SME

가 , APEC SME ,
SME 가

APEC HRD
가,

(current management practices)
가 . 가
가 .

4.

,
, APEC 가
.

(a flexible workforce)

(skills standards)
(skills standards system)

APEC

5.
가

, 가

, APEC

(mobility)

가

6.

APEC

1995

1996

;

a. APEC

(APEC Leaders Education Initiatives)

UMAP

APEC

APEC

(establishment)

b.

c.

(engineering)

(accounting)

(surveying)

. 가

, 2 가 :

1. 가 1 APEC HRD ;

2. 가 2 APEC HRD 가

.

1995

, APEC HRD

(1)

- 1 :
- 2 :
- 3 : 가
- 4 : (Working Life)
- 5 : , ,
- 6 :
- 7 :

EDFOR	1	2	3	4	5	6	7
(1)	x						x
	x			x	x		x
	x					x	
	x						x
	x			x	x	x	x
	x				x	x	x
	x					x	x
	x				x	x	x
가	x				x		x
21	x					x	x
			x				x

HURDIT	1	2	3	4	5	6	7
			x				
OJT			x				
							x
					x		
APEC 가		x					
					x		
APEC						x	x
						x	x
APEC			x				x
HRD Outlook HRD					x		
- HRD						x	x

NEDM	1	2	3	4	5	6	7
		x		x	x	x	x
HRD	x			x	x	x	x
			x				
HRD			x	x	x		x
		x		x			x
HRD		x		x		x	x
		x				x	
		x	x				
APEC , ,	x	x				x	
, ,	x		x	x			

BMN	1	2	3	4	5	6	7
			x				
가			x				
(cross-cultural)				x	x		
				x			x
(cross-cultural)				x			x
HRD				x	x	x	
					x		x
					x		x
				x	x	x	
EDZ				x	x		
			x	x			x
APEC			x	x			x
				x			
가				x	x		x
HRD			x	x	x		x
APEC							x

HRD (2)

	1	2	3	4	5	6	7	S L	/		
	x								EDFOR	1995	1996
	x								EDFOR	1995	1996
HRD		x						L	PECC & / NEDM	1995	1996
APEC 가		x						S	HURDIT	1995	1996
		x						S	RP	1996	1996
				x					Cross- Network	1995	1996
			x					S	BMN	1995	1996
			x					S	BMN	1995	1996
HRD					x				HURDIT	1995	1996
				x				L			
						x		L	ALEI	1995	1996
					x				HURDIT	1995	1996
HRD						x		S	Tourism		1996
, ,						x		S		1995	1996
							x	S	BMN	1995	1996
HRD							x	S	RP/ NEDM	1996	1996
APEC APEC						x		L	EDFOR/ ALEI	1995	1996
APEC							x	L	PRC/ BMN	1995	1996
. HRD			x					L	NEDM/	1995	1996
.		x						L	NEDM/	1995	1996

:

S -

L -

	1	2	3	4	5	6	7	S L	/		
: EDM					x			L	NEDM /	1995	1996
APEC		x	x					S	HURDIT / RP	1996	1997
			x			x		S	HURDIT / RP	1996	1997
		x						L	Transpo/	1995	1996
			x					L	Transpo/	1995	1996
			x					S	Agri/ Transpo	1995	1996
							x	L	Transport	1995	1996

APEC

1997

HRD

1997

- HRD APEC 1995 11 HRD (HRD Action Program) (Osaka Action Agenda) HRD APEC
- (Draft Action Plan) HRD
- 1997 , APEC HRD HRD HRD

(substantive input)

- , , “ (stock taking)” 가
- APEC (direction) APEC fora
(expected outcomes)
- (reporting responsibilities)

· 1997 , :

· HRD HRD 5가

· HRD

· APEC (APEC-Wide Strategies on SMEs)

. (Organizational Review)

. /

. (Medium Term Priorities)

. , , .

. HRD

HRD

5가

1996 1

, HRD

5가

,
1997 9

가 .

(Action)			
1. /	HRD	LMI	1997 9 HRD
2. (Strenghtening)	APEC		1997 9 HRD
3. HRD (Mobility)	(1st Working Group) (Industry Science and Technology)	HURDIT	1997 9 HRD (1997 9)
4.	/	CTI	1997 9 HRD
5.		BMN ()	1997 9 HRD

. HRD

2 HRD 가 1997 9

. HRD

가

(Action)			
1.			1997 1 - 9
2.			1997 1
3.			1997 5
4.	/		TBD 1997 5 - 9
5.		HRD	1997 9

•
HRD APEC (ABAC) . APEC ,
가 . ,
APEC ,
1997 : HRD
; “ (lessons learned)” ;
HRD APEC 가 .

(Action)			
<p>가 HRD “ (Lesson Learned)” ; HRD HRD ; APEC</p>	<p>· HRD · ABAC</p>	<p>TBD(/)</p>	<p>1997 5 HRD</p>

(Organizational Review)

APEC 가

HRD

HRD

가

(Action)			
HRD 가		()	

. 1996 6 , HRD /

HRD (HRD Action Program)
1996 6 ,
8가 . (:
HRD (HRD Working Group Matrices) , .
1996 :
가 .)

SF =
CF =
TILF = TILF

(Action)			
<p>(CF: HRD 08/ 96)</p> <p>(: ,</p> <p>5)</p>	<p>1 :</p> <p>(Basic Education)</p>	<p>HRD Matrices</p>	<p>HRD Matrices</p>

(Action)			
<ul style="list-style-type: none"> · APEC (CF: HRD 03/ 96) · HRD (SF) · APEC 97/ 98 HRD (SF) · LMI (SF) · LMI (SF) · LMI (SF) 	<p>2 :</p> <p>/</p>	<p>HRD Matrices</p>	<p>HRD Matrices</p>

(Action)			
<ul style="list-style-type: none"> · APEC (CF: HRD 14) · (CF: HRD 14) · CD ROM (CF: HRD 14) (8) · HRD (CF: HRD 05/ 96) · APEC (CF: HRD 07/ 96) · (CF: HRD 09/ 96) 	<p>3 :</p> <p>가</p> <p>, 가</p> <p>,</p>	<p>HRD Matrices</p>	<p>HRD Matrices</p>

(Action)			
<ul style="list-style-type: none"> · 가 HRD (CF: HRD 10/ 96) · APEC HRD: 가 (CF: HRD 01/ 95) · APEC (CF: HRD 09/ 95) · (SF)(5) · ACTETSME (SF) · APEC 가 (SF) · APEC CHRO [HRD (SF)] 	3		

(Action)			
. (CF: HRD 01/ 96)	4 :	HRD Matrices	HRD Matrices

(Action)			
<ul style="list-style-type: none"> · (CF: HRD 04/ 96) · (CF: HRD 18/ 95) · (SF) · (SF) · 가 (SF) · (SF) · (SF) , 	<ul style="list-style-type: none"> 5 : , , · 	<p>HRD Matrices</p>	<p>HRD Matrices</p>

(Action)			
<ul style="list-style-type: none"> · (CF: 가 HRD 14) · (Best Practices): , · (SF) · (SF) · JAPET: APEC (SF) · (SF) · (SF) 	<p>6 :</p> <p>:</p>	<p>HRD Matrices</p>	<p>HRD Matrices</p>

(Action)			
. : (SF)	7 :	HRD Matrices	HRD Matrices

(Action)			
<ul style="list-style-type: none"> • (TILF; Trade and Investment Insurance Training Program) (1996 10) • HRD (CF: HRD 14) • APEC (CF: HRD 14) • HRD (CF: HRD 02/ 96) • (CF: HRD 11/ 95 HRD 06/ 96) • (CF: HRD 10/ 95) 	<p style="text-align: center;">8 :</p> <p style="text-align: center;">HRD ;</p> <p style="text-align: center;">HRD/HRD</p>	<p style="text-align: center;">HRD Matrices</p>	<p style="text-align: center;">HRD Matrices</p>

(Action)			
<ul style="list-style-type: none"> · (SF) · HRD (SF) · (SF) · HRD APEC (SF) 	8		

(Medium Term Priorities)

HRD 1 , HRD 5 / 6
 APEC HRD

(Action)			
TBD	TBD	TBD	TBD

HRD
(ANNUAL WORKPLAN)

1998

Office of the Lead Shepherd
Human Resources Development Canada
Draft, June 10, 1998

HRD WORKING GROUP

1998

HRD WG , 1995 11 (Osaka Action Agenda) APEC
(Leaders and APEC Ministers) HRD (HRD Action Program)
, 1994 (Jakarta Declaration on a Framework for Human
Resources Development)

HRD WG , 1997 HRD Working Group 8

APEC 1997 , 21 HRD
Working Group . 1997 11
APEC .

HRD APEC 가 . HRD , 6
1 , 1998 (key theme) .
, HRD Working Group ,
APEC HRD
가 .

Working Group , 1998 1997

1 Working Group 8 .

8 , (HRD Ministers), APEC , APEC

가

(APEC Central Operational Account: CF) TILF (TILF) , APEC (SF)

(lead network) 가 가(lead economy)

Office of the Lead Shepherd가 HRD Working Group

Office of the Lead Shepherd Network Coordinators, HRD Working Group , APCE

Office of the Lead Shepherd DB Office of the Lead Shepherd가 1998 4

7

가 , 가 , (addenda)
18 Working Group 가 DB
가 가
HRD Working Group

Office of the Lead Shepherd
Human Resources Development Canada

1. -

(4 5)	1997 9 HRD (HRD Ministerial Direction) , 1997 11 APEC		
(4, 5 8)	1997 9 HRD (HRD Ministerial Direction) , 1997 11 APEC		
(4, 5 7)	HRD , 1997 11 APEC		

2 - 가

	1997 9 HRD (HRD Ministerial Direction) , 1997 11 APEC .		

3 - 가, (sustainable growth and development) .

(SMEs)	1997 , . 1997 11 APEC , APEC		
APEC 가 , , 가	1997 11 , (Leaders' commitment)		

4 - , , , , .

APEC (5)	1997 9 HRD (Leaders' Initiative)		
APEC Camp) (8)	(Youth Skill HRD 1997 11		1997 12 ,
, (1 5)	1997 9 HRD 1997 11 APEC .	,	
, (1, 5 8)	1997 9 HRD 1997 11 APEC .	,	
, , ,	1997 9 HRD 1997 11 APEC .	,	

()

4 - , , , ,

(mentoring)	1997 9 HRD 1997 11 APEC		
(7)	HRD , 1997 11 APEC		
(1, 5 7)	HRD , 1997 11 APEC		
	1997 9 HRD , 1997 11 APEC		

5 - , , , 21

. (, , ,)

APEC (4)	1997 9 HRD (Leaders' Initiative)		
(1 4)	1997 9 HRD , 1997 11 APEC .		
(1, 4 8)	1997 9 HRD , 1997 11 APEC .		
(8)	HRD , 1997 11 APEC .		
, , (administrators)	1997 9 HRD		

()

5 -

21

(1, 4 7)	HRD 11 APEC .	, 1997	
	1997 9 HRD		
(4)	1997 9 HRD 1997 11 APEC .	,	

6 -

, 가

	1997 Ministerial)	'deliverable' ABAC (SME	

7 - 가

, , , .

(4)	HRD , 1997 11 APEC .		
(1, 4 5)	HRD , 1997 11 APEC .		
, , , , .	3 1997 9 HRD , 1997 11 APEC .		

APEC (Youth Skill Camp) (4)	HRD 1997 11		1997 12 ,
(electronic sourcebook)	HRD , 1997 11 APEC	가 1998	
	HRD , 1997 11 APEC		
	ABAC , , APEC , HRD .		
	HRD , 1997 11 APEC		
	1997 11 , APEC HRD Working Group .		

()

8 -

(1, 4 5)	1997 9 HRD 1997 11 APEC		
가	1997 11 , HRD APCE		
APEC (Education Hubs)	1997 11	가	
1999 가 (Ministerial Conference on Education)	1997 11		
(5)	HRD 11 APEC , 1997		
APEC	1997 11 , HRD APEC		
HRD Working Group, 1998 APEC	1997 9 HRD 1997 11 APEC		
APEC HRD	2 HRD		

1. -

<p>(1) (SF)</p> <p>5</p>	<p>가</p>	<p>- : EDFOR - : - : 가 (economies)</p>	<p>, 1998 6 .</p>
<p>HRD :</p> <p>(1) (SF)</p> <p>4, 5 8</p>	<p>1.</p>	<p>- : BMN - : - : , , , , , , , , ,</p>	<p>1. 가 . , http:// www.sphere.ne.jp/ indl/ 가 . 2. 10 BMN , 1997 APEC Working Group Deborah East West Center Sharkey가 .</p>

(1)

			3. 1998 6 20 HRD WG , 가
(CF)	1. 가	- : EDFOR : : , PNG, ,	1. 6 (, , , , ,) ,) , 가 2. , 가 3. , , 1997 9 가 4. 1997 12 , ,
5 .			

2 - 가

<p>APEC (1 -APEC LMI) (CF)</p>	<p>1. LMI , , , APEC 가 . 2. APEC LMI , LMI . 3. "APEC " LMI , 1998 12 , LMI</p>	<p>- : LMI - : - : 가</p>	<p>APEC LMI 1985-1996 . 1998 1 , 1997 , 가 . . 1998 APEC . () (,)</p>
--	---	----------------------------------	--

(2)

<p>(CF)</p> <p>7 .</p>	<p>1. , HRD</p> <p>2. , APEC</p>	<p>- : NEDM</p> <p>- :</p> <p>- : , ,</p> <p>, , ,</p> <p>PNG, , ,</p> <p>, ,</p>	<p>1. 1997 5</p> <p>HRD Working Group</p> <p>, 1997 7 BAC</p> <p>1998 6 .</p>
<p>(Symposium on Overcoming Bottlenecks: Freer and More Open Labor Markets)</p> <p>(SF)</p> <p>6 .</p>	<p>1. , 가</p> <p>APEC 가</p> <p>2. APEC</p>	<p>- : NEDM</p> <p>- :</p> <p>- :</p> <p>가</p>	<p>1. 1997 5</p> <p>HRD Working Group</p> <p>, 1997 7 BAC</p> <p>2. 1998 1 18</p> <p>.</p>

(2)

<p>LMI APEC LMI ()</p>	<p>1. 가 ,</p>	<p>- : LMI - : - :</p>	<p>APEC LMI 가</p>
<p>APEC (CF) 7</p>	<p>1. 가 가 2. 가 가 APEC-LMI 가 3. 가 가</p>	<p>- : NEDM - : - : , , , , , , , ,</p>	

3A - , 가,

(SF)	<ol style="list-style-type: none"> 1. 2. 3. , 4. 5. 6. APEC 가 , , 7. APEC 	<ol style="list-style-type: none"> - : BMN - : 가 - : 	<ol style="list-style-type: none"> 1. 1997 5 HRD Working Group , 1997 7 BAC . 2. , 가 .
APEC HRD (SF)	<ol style="list-style-type: none"> 1. HRD 2. APEC HRD 3. HRD 4. HRD 	<ol style="list-style-type: none"> - : HURDIT - : - : , , , , 	<ol style="list-style-type: none"> 1. 1997 5 7 , 2. , APEC HURDIT 3. 가 . 1998 5 18-20 .

(3A)

<p>APEC</p> <p>(TMS)</p> <p>(SF)</p>	<p>1. , APEC</p> <p>2. NIKKEIREN TMS</p> <p>3. NIKKEIREN ,</p> <p>Nikkeiren (NICC)</p> <p>NIKKEIREN</p>	<p>- : BMN/ HURDIT</p> <p>- : , ,</p> <p>- : , ,</p> <p>PNG, ,</p>	<p>1. 1997 11 12 , 9 16</p> <p>가 6</p> <p>2.</p> <p>HRD</p> <p>Working Group</p>

(3A)

(CHRO) 2	1. APEC 가, ,	- : BMN	1. BMN , 1 가
(CF) (1)	BMN	- : , , ,	, 1 1998 1
	2. CHRO ,		2. , ,
	3. CHRD , APEC HRD HRD		background paper 3. , , 1998 6
8	4. 5. APEC HRD APEC		23-24 4.

(3A)

<p>(Business and Technology Incubator Managers)</p> <p>(SF)</p> <p>8</p>	<p>1. ,</p>	<p>: BMN</p> <p>:</p> <p>:</p> <p>, , ,</p> <p>, ,</p>	<p>1. /</p> <p>가 1997</p> <p>가</p>
<p>APEC 가</p> <p>(: HRD)</p> <p>(CF)</p>	<p>1. ,</p> <p>ISO 9000</p> <p>14000</p> <p>, ISO 9000 14000</p> <p>,</p>	<p>: BMN</p> <p>:</p> <p>:</p> <p>, , ,</p> <p>가 ,</p>	<p>1. 1997 8 SCSC</p> <p>HRD WG</p> <p>. SCSC HRD WG</p> <p>(AIM</p> <p>Philippine) 1997 12</p> <p>19 / 가</p> <p>. 8 11 가</p> <p>가 .</p> <p>(MNCs),</p> <p>NGO, 49 가 .</p>

(3A)

<p>(SF)</p>	<p>1. APEC 가</p>	<p>- : Leader's Initiatives - :</p>	<p>1. 1997 3 , 11 focal points 2. 1 Focal Points 1997 6 18-19 , 가 focal points , 가 가 가 BVPCO 가</p>
<p>: APEC 가 (CF) 8</p>	<p>1. , APEC (HRM) 2. 가 HRM</p>	<p>- : HURDIT - : - : , , , , ,</p>	<p>1. : 6 HRM , 3 , 1 2. 1999 1</p>

(3A)

<p>APEC 가</p> <p>(CF)</p> <p>5 8</p>	<p>1. APEC</p> <p>2.</p> <p>3. APEC 가 , 가</p> <p>4. (Senior Officials)</p>	<p>- : HURDIT</p> <p>- :</p> <p>- : , ,</p>	<p>1. 1997 5 HRD WG ,</p> <p>1997 7 BAC</p> <p>1997 12 .</p> <p>2. 1998</p> <p>3.</p> <p>4. 1998 10</p> <p>5. APEC , Australian Aid Agency , 가 ,</p> <p>6. 18 APEC HRD WG .</p>
--------------------------------------	--	---	---

(3A)

<p>APEC (CF)</p>	<p>1. ,</p>	<p>- : BMN - : , - : , , ,</p>	<p>1. 가 2. , , , 1997 10/ 11</p>
<p>APEC (CF)</p>	<p>1. facilitator , 2. , , ,</p>	<p>- : HURDIT - : ,</p>	<p>1. , 1997 1 2 . , , 1999 12 2 2. , , , APEC 3. 1998 8 24 8 28 가 .</p>

(3A)

: (SF)	1. 가	- : BMN - : , ,	
(SF) 5 8	1. 2. APEC 가 가 가 , 가 .	- : HURDIT - : , , , - : , , , PNG, ,	, 1 6 1997 , . 1997 778 . 가가 . 가 가

3B -

<p>(CF)</p> <p>CD-ROM</p> <p>8</p>	<p>1. CD-ROM 가</p>	<p>: BMN</p>	<p>1. 1997 (kick-off meeting)</p> <p>2. 1997 가</p> <p>3. 1997 9 , APEC APEC</p> <p>4. 가</p> <p>5. CD-ROM</p> <p>1998</p>

(3B)

<p>APEC Center (ACTETSME) (SF)</p> <p>8</p>	<p>1. APEC , APEC 가</p> <p>2. , , , ,</p>	<p>- : NEDM - : - :</p>	<p>1. ACTETSME ,</p> <p>2. /</p> <p>a) : 1997 3 17-21</p> <p>b) : 1997 4 16-30</p> <p>c) APEC : 1997 6 18-20</p> <p>d) APEC : 1997 8 20-22</p> <p>e) : 1997 10 23-25</p>
	<p>1998</p>	<p>- : BMN - : - :</p>	<p>1996 12 가 .</p>

(3B)

(SF)	1. 2.	- : HURDIT - :	
2 APEC -MITEC '98 (SF)	1. , APEC	- : HURDIT - : - 가 :	
APEC (CF) 8	1. APEC 2. APEC 가 3. APEC 가	- : HURDIT - :	1. , 1997 1 2 1999 12 .

3C - 가

<p>APEC 가 (2 :) (SF)</p>	<p>1. 2 , , APEC 가 () 2. , , 가 , , 가 , .</p>	<p>- : BMN -</p>	<p>1. 1997 5 가 HRD WG , 1997 7 BAC 2. , 가 (Sustainable Development Ministers) 3 APEC WG 가 3. 1997 6 , Energy WG 가 , 1997 9 가 4. , 1997 11 APEC 가</p>
-----------------------------------	---	----------------------	--

(3C)

<p>APEC (CF)</p>	<p>1. , APEC , APEC production (CP) processes) (cleaner CP HRM 가 , 가 , CP APEC APEC 가 , HRM CP</p>	<p>: BMN 가 : , , , , , , ,</p>	<p>1. 1 : (1997 9-11), 1 (1997 11 17-18), , 가 (1997 11 -1998 1), 가 (1997 11 -1998 1), CO HRM 가 (1998 1-2) 2. 2 : (가 , , ,) (1998 1-3), 가 가 91998 1-4), (1998 2-5), 가 (performance indicators) (1998 3-5) 3. 3 1 (1998 5), , (, 1998 5-6), 가 (1998 5-7), (1998 7-9), (1998 10), (1998 10)</p>
----------------------	--	--	---

(3C)

<p>가 (2)) (SF)</p>	<p>1. 가 2. 가 3. (, APEC) , 가 , HRD 가 .</p>	<p>- : BMN - : - 가 : , , , , , , ,</p>	<p>1. (97 7 -98 5) 2. APEC 가 () 3. 가 (98) 4. (98) 5. , , 6. (1998)</p>
---------------------------------	--	--	---

(3C)

: APEC 가 (가) (CF)	1. 가 , 가 .	- : BMN - : - 가 : , , , ,	1. . 98 3 2. 98

4 - , , , ,

<p>21 (SF) 7</p>	<p>1. 2. APEC 3. APEC 가 4. HRD</p>	<p>- : NEDM - : - 가 : , , , , , , , , ,</p>	<p>1. 가 , (coordinator) 1 2. 가 98 6 13-14 3. 가 APEC HRD WG , 9 APEC 4. 98 12</p>

(4)

<p>HRD : 1.</p> <p>(1) (SF)</p> <p>1, 5 8</p>	<p>1.</p>	<p>: BMN</p>	<p>1. 가</p> <p>http:// www.sphere.ne.jp/ ind1/ 가 .</p> <p>2. 10</p> <p>BMN , 1997 APEC Working Group East West Center Deborah Sharkey가</p> <p>3. 1998 6 20</p> <p>HRD WG 가 ,</p>
--	-----------	--------------	--

(5)

<p>HRD : (1) (SF) 4, 5 8</p>	<p>1.</p>	<p>: BMN : : , , , , , , , , ,</p>	<p>1. 가 . http://www1.sphere.ne.jp/indl/ 가 . 2. 10 BMN , 1997 APEC Working Group East West Center Deborah Sharkey가 . 3. 1998 6 20 HRD WG 가 ,</p>
---	-----------	--	---

(5)

(1) (SF) 1 .	가 , ,	- : EDFOR - : - : 가 (economies)	, 1998 6 .

(5)

<p>APEC 가 (CF) 3 8</p>	<p>1. APEC 2. , 3. APEC 가 가 4. , , (Senior Officials)</p>	<p>- HURDIT : - : , , , :</p>	<p>1. 1997 5 HRD WG , 1997 7 BAC 1997 12 2. 1998 3. 4. 1998 10 5. APEC Aid Agency , 가 , 6. 18 APEC HRD WG</p>

(5)

<p>(CF)</p>	<p>1. 2. 3-4 3. APEC</p>	<p>- : EDFOR : 가 : , , , , , ,</p>	<p>1. 1997 5 HRD WG 가 , 97 7 BAC 2. 98 1 가</p>
<p>(SF)</p> <p>3 8</p>	<p>1. 2. APEC 가 가 가 가</p>	<p>- : HURDIT : : , , , PNG, ,</p>	<p>6 , 1 , 1997 , 1997 778 가가 가 가</p>

6 -

, 가

(SF)	<p>, APEC</p> <p>-1 : , ,</p> <p>-2 A:</p> <p>-2 B:</p> <p>B (UMAP), 2 A</p>	<p>-</p> <p>EDFOR :</p> <p>- 가 :</p>	<p>1,2</p> <p>. 3</p> <p>6 18 HRD WG</p> <p>3 , APEC</p> <p>가</p> <p>,</p> <p>,</p>
------	--	--------------------------------------	---

(6)

<p>(CF) 가</p>	<p>1. APEC , , - 2. APEC . HURDIT 가 : 가 : 3. 4.</p>	<p>- : LMI : 가 :</p>	<p>: 1. 2 7 가 97 2 2. 97 3 HURDIT , 가 , , , 가 , , 3. 가 , ,</p>
<p>(SF)</p>	<p>, 가</p>	<p>- : LMI : 가 :</p>	<p>가</p>

(6)

<p>-APEC , (JAPET) (SF) 8 .</p>	<p>1. 2-3 APEC 2. .</p>	<p>- Minister's Initiative - : - 가 : , , , , ,</p>	<p>: 1. 97 6 , 가 가 . 2. 97 50 가 11 .</p>
<p>(UMAP) (SF) 8</p>	<p>, , .</p>	<p>- EDFOR - :</p>	<p>: 1. UMAP Reference Group 98 8 2. UMAP 98 ' 12 ' .</p>

7 - 가 , , , .

(SF)	1	<p>1. NEDM</p> <p>2. 가 :</p> <p>3. , , , 2.</p> <p>4. ,</p> <p>가</p>	<p>1. 6 가</p> <p>/ 가</p> <p>2. ,</p> <p>. 99</p> <p>3. 가</p> <p>. 98</p> <p>가</p> <p>, 99</p>

(7)

<p>(SF)</p> <p>4</p>	<p>: 21</p> <p>1.</p> <p>2. APEC</p> <p>3.</p> <p>APEC 가</p> <p>4. HRD</p>	<p>- NEDM</p> <p>- 가 :</p> <p>,</p> <p>,</p> <p>,</p> <p>,</p> <p>,</p>	<p>: 1. 가 , (coordinator) 1</p> <p>2. 가 98</p> <p>6 13-14</p> <p>3. 가 APEC HRD WG , 9 APEC</p> <p>4. 98 12</p>
----------------------	--	---	--

(7)

<p>(CF)</p> <p>2 .</p>	<p>1. , HRD</p> <p>2. , APEC</p>	<p>- : NEDM</p> <p>- : ,</p> <p>- : , , PNG,</p> <p>- : ,</p>	<p>1. 1997 5</p> <p>HRD Working</p> <p>Group</p> <p>1997 7 BAC</p> <p>1998 6</p>
<p>APEC</p> <p>(CF)</p> <p>3 .</p>	<p>1. APEC</p> <p>2. APEC 가</p> <p>3. APEC 가</p>	<p>- : HURDIT</p> <p>- :</p>	<p>1. , 1997</p> <p>1</p> <p>2</p> <p>1999 12</p>

(7)

<p>가 (TILF)</p>	<p>1. 가 2. 3. (GTAP)</p>	<p>- NEDM : - : - 가 : , 가 , , 가 ,</p>	<p>97 5 WG 가 . TILF 97 9 BAC .</p>
<p>APEC (CF) 2 .</p>	<p>1. 가 가 2. 가 가 APEC-LMI 가 3. 가 가</p>	<p>- NEDM : - : - : , , , , , , , ,</p>	

<p>APEC (SF)</p>	<p>1. 2.</p>	<p>- HURDIT : - 가 :</p>	<p>1. 97 5 26-29 16 HRD WG 가 2. 가 3. 가 4.</p>
<p>APEC (SF)</p>	<p>1. UMAP</p>	<p>- Leader's : Priorities - 가 :</p>	
<p>APEC Study Centers (SF)</p>	<p>1. APEC APEC Study Center 2. APEC APEC 3.</p>	<p>- Leader's : Priorities - 가 : , , , , , PNG, , 가 , ,</p>	<p>APEC Study Center 97 5 , Study Center 가 APEC Reader APEC , APEC</p>

(8)

<p>APEC (SF)</p> <p>5</p>	<p>1. APEC ,</p> <p>2. APEC ,</p> <p>3. APEC 가</p> <p>4.</p> <p>APEC 가</p> <p>5. APEC</p>	<p>- :</p> <p>- :</p> <p>가 :</p> <p>,</p> <p>,</p> <p>,</p>	<p>1. , 가 ,</p> <p>,</p> <p>,</p> <p>가 CDS-SIS</p> <p>2.</p> <p>3. APEC HRD</p> <p>98</p> <p>2</p> <p>4. 2 ,</p> <p>(CAD),</p> <p>(FA), (</p> <p>),</p> <p>50 가</p>
-------------------------------	---	---	---

(8)

<p>CD-ROM (CF) 3</p>	<p>1. CD-ROM 가</p>	<p>: BMN : : , , , ,</p>	<p>1. 1997 (kick-off meeting) 2. 1997 가 3. 1997 9 , APEC APEC 4. , 가 5. 1998 , CD-ROM</p>
<p>APEC (SF)</p>	<p>1. APEC 2. 3. 96 A) B) , C) D) E)</p>	<p>: EDFOR : : 가 :</p>	<p>1. 97 7 , (office of the Grants and Programs Secretariat)가 , AEF 가 97 가 . 97 12 , 5 1000 1 .</p>

(8)

<p>APEC Center (ACTETSME) (SF)</p> <p>3</p>	<p>1. APEC 가 , APEC</p> <p>2. ; , ,</p> <p>3. .</p>	<p>- : NEDM</p> <p>- :</p> <p>- :</p>	<p>1. ACTETSME ,</p> <p>2. /</p> <p>a) : 1997 3 17-21</p> <p>b) : 1997 4 16-30</p> <p>c) APEC : 1997 6 18-20</p> <p>d) APEC : 1997 8 20-22</p> <p>e) : 1997 10 23-25</p>
<p>(SF)</p>	<p>1. 가 ,</p> <p>2. 가 , ,</p> <p>3. .</p>	<p>- EDFOR</p> <p>- : - 가 : ,</p>	<p>: 1. 95 1</p> <p>2. 97 3 , 1 3 ,</p> <p>3. APEC .</p>

(8)

<p>: APEC 가 (CF) 3</p>	<p>1. , APEC (HRM) 2. , 가 HRM .</p>	<p>- HURDIT : - : - : , , , ,</p>	<p>1. HRM : 6 , 3 , 1 2. 1999 1</p>
<p>21 (SF)</p>	<p>1. : 가 , 2. 3. APEC , , 4. 21 5. APEC</p>	<p>- EDFOR : - : - 가 :</p>	<p>1. 97 5 HRD WG 가 , 97 7 BAC .</p>

(8)

<p>HRD : (1)) (SF)</p> <p>1, 4 5</p>	<p>1.</p>	<p>: BMN</p>	<p>1. 가</p> <p>http://www1.sphere.ne.jp/indl/ 가 .</p> <p>2. 10</p> <p>BMN , 1997 APEC Working Group East West Center Deborah Sharkey가</p> <p>3. 1998 6 20 HRD WG 가 ,</p>
---------------------------------------	-----------	--------------	---

(8)

<p>APEC 가 (SF)</p>	<p>6 , " APEC" , , APEC .</p>	<p>- : EDFOR - : 가 : , , , , , , , PNG, , ,</p>	<p>: 1. 가 98 6 2. 98 , 7-12 3. 3 - , APEC 가 .</p>
<p>APEC (SF)</p>	<p>1. 2. , (OJT), (Off-JT) 3. 가 APEC 가</p>	<p>- : NEDM - : 가 : , , , , , , ,</p>	<p>98 12 1 , 12 4</p>

(8)

<p>-APEC (SF) (JAPET) 6</p>	<p>1. 2-3 APEC 2.</p>	<p>- Minister's Initiative - 가 :</p>	<p>1. 97 6 , 가 2. 97 50 11</p>
<p>21 (SF)</p>	<p>1. APEC Study Center 2. Study Center APEC</p>	<p>- EDFOR - 가 :</p>	<p>1. APEC Study Center 가 2 ("21 : APEC ") 95 9 2. 3 97 3 3. 4. 가 99</p>
<p>(SF)</p>	<p>1.</p>	<p>- EDFOR - 가 :</p>	<p>18 HRD WG ,</p>

(8)

<p>(UMAP) (SF)</p> <p>6</p>		<p>- EDFOR : - 가 : , , , , , , ,</p>	<p>1. UMAP 97 11 14 , UMAP UMAP</p> <p>2. : 97 6 23-26 , 7 8-10</p> <p>3. 97 UNESCO UMAP가 .</p> <p>4. 97 8 19-24</p> <p>5. 97 12 UMAP가 . (AUAP) 2 UMAP가 .</p> <p>6. 98 8 25-27 UMAP Reference Group 가 .</p>
---------------------------------	--	--	---

H R D

9 9 1 1 2

,

8

1. .
2. ,
3. , 가, ,
4. , ,
5. , , , 21

6.

7.

8.

H R D

, 9 9 1 1 2

HRDWG 11 “ ” “ HRD
94 ” “ ”
97 1 , HRDWG가 8
97 APEC HRD , 21 HRDWG
9 8 1 1 APEC
APEC HRD 2000 APEC 가

HRD APEC APEC

HRDWG가 .

97 1 8

가 , 가,

가 가

가 가

HRDWG APEC 가 “ ”, “ HRDWG ” , APEC ,

99

99

I .

1 .

,

APEC 가 가 . APEC . "

가 가 . HRD .

가 가 .

2 .

APEC " (Capacity Building) "

.

APEC , , ,

- 3 . HRD가 21 , 가 . 9 8
APEC , HR DWG
- 4 . ECOTEC .
WG A P E C "
- 5 . " 2 1 , APEC "
- 6 . APEC
A P E C APEC
- 7 . APEC 2 0 0 0 9 9 APEC
APEC
9 9 9

II .

1.

1 (SF)		: BMN	1. : http://www1.sphere.ne.jp/mdl/ 2. 1998. 6. 20 3. 1999. 6

2.

<p>APEC APEC LMI)</p> <p>(1 -</p>	<p>LMI</p> <p>가</p> <p>LMI - " APEC "</p> <p>98 12 가 LMI</p>	<p>: L M I</p> <p>⋮</p>	<p>1 9 8 5 - 1 9 9 6 :</p> <p>L M I</p> <p>가 . 98</p> <p>APEC</p> <p>()</p> <p>()</p> <p>99</p>

APEC (CF)	APEC APEC LMI , , , , , . . .	APEC : L M I : : HRDWG	18 WG BAC . 99 1 1 99 12 31 . 6 30 .

APEC (CP)	가 가 , , LMI APEC	:: NEDM : : , , , , , , , ,	

3A :

, 가, , .

<p>CEO</p>	<p>CEO 가 CEO APEC 가 APEC</p>		<p>97 5 HRDWG BAC 97 7 가 가</p>
<p>HRD (SF)</p>	<p>HRD APEC To reveal HRD program and policy preferences of APEC HRD HRD HRD</p>	<p>: HURDIT : 가 : , , , , ,</p>	<p>HURDIT APEC .. 98 5 18-20</p>

(SF)	가	: BMN : : , , , , , , , ,	가 , 가 97 가
APEC -2 CEO	APEC CEO .	: BMN : : , , , , , , , , ,	19 HRDWG BAC .. 98 1 2 가 . CHRO 97 1 . 19 HRDWG CHRO BMN APECWG ..

3A ()

<p>Business Volunteer Program) (SF)</p>	<p>1. APEC 가</p>	<p>: LEADER ' S INITIATIVES : : , , , ,</p>	<p>: www.apecsec.org.sg; www.actetsme.org.ph , 9 8 4 B V P 가 9 8 8 4. 9 8 1 BVP CO 6</p>
<p>: APEC (2) (CF</p>	<p>APEC 가 HRM</p>	<p>: HURDIT : : , , , , , , , ,</p>	<p>가 : 8 3 HRM 가 1 2. 가 / 97 1</p>

<p>가 .</p> <p>∴ APEC</p>	<p>APEC</p> <p>APEC</p> <p>,</p> <p>r .</p> <p>ㅓ ,</p>	<p>: HURDIT</p> <p>:</p> <p>:</p> <p>,</p> <p>,</p>	<p>97 5 HRDWG</p> <p>97 7</p> <p>BAC</p> <p>.</p> <p>97 12</p> <p>98 .</p> <p>.</p> <p>가</p> <p>.</p> <p>98 10</p> <p>APEC</p> <p>가 ,</p> <p>가 ,</p> <p>가</p> <p>.</p>
--------------------------	--	---	--

3 ()

<p>APEC (CF)</p>		<p>: HURDIT : : , ,</p>	<p>97 1 99 12 APEC 98 8 24 28</p>
<p>(SF)</p>	<p>: 1.</p>	<p>: BLM : : , ,</p>	
<p>(SF)</p>	<p>APEC APEC 가 가</p>	<p>: HURDIT : : , , , , , , , ,</p>	<p>97 6 97 . 97 778 가가 가 가</p>

B.

<p>CD_ROM (CF)</p>	<p>1. : ,</p>	<p>: BMN : : , , , , , , ,</p>	<p>1.1997 1 2.1997 1 3.1997 9 , APEC APEC 4. 가 5. 1998 CD-ROM ,</p>
<p>(SF)</p>	<p>: 가 CTI-DMEG, HRD-BMN APEC 가 가</p>	<p>: BMN : : , , , , , , , , ,</p>	<p>1. 19 HRD BAC 2.1998 6 -11 ADR 가 3.1998. 11. 13, 4.1999 4</p>

3B ()

<p>SMEs</p> <p>APEC</p>	<p>1 . APEC APEC SMEs</p> <p>2 . SMEs</p>	<p>: NEDM</p>	<p>2 .</p> <p>(a) 97 3 17-21 : SMEs</p> <p>(b) 97 4 16-30 : 가</p> <p>(c) 97 6 18-20 : APEC SMEs 가</p> <p>(d) 97 8 20-22 : APEC SMEs</p> <p>(e) 97 10 23-25 :</p>
<p>(SF)</p>	<p>SMEs 가</p>	<p>: HURDIT</p>	
<p>2 APEC SMEs ?</p>	<p>APEC</p>	<p>: HURDIT</p>	<p>1. 98 9 가 가 19</p>

3 C : ,

<p>APEC 가 II :) (SF)</p>	<p>II ?APECWG</p>	<p>: BMN : USA</p>	<p>97 5 HRDWG 97 7 BAC "가 가 APEC WG 3 가 3 1997 6 WG 가 가 9 97 " " 가 97 ' 11 APEC 가</p>
-------------------------------	-----------------------	------------------------	---

3C: ()

(CF)	<p>1. : . . 가 . 가 가 APEC APEC 가 , 가</p>	<p>: BMN : : , , , , , , , ,</p>	<p>1. 1: (1997.9-11) 1 가 (97.11.17-18). () (97.11-98.1) . HRM 가 (98.1-2) 2. 2: , , (98.1-3). 가 (98.1-4). (98. 2-5). (98.3-5). 3. 3: , , (98.5). (, 98.5-6). 가 가(98.5-7). (98.7-9). (98.10). (98.10)</p>

3 C ()

<p>가 APEC (SF)</p> <p>II)</p>	<p>가 가 ..; () APEC 가 , , HRD 가</p>	<p>: BMN : ; : , ' , ; '</p>	<p>97 7 - 98 5 :</p> <p>. : 3</p> <p>가 APEC</p> <p>98 가 : 3</p> <p>가</p> <p>98 : 가</p> <p>' 가 98 :</p>
--	---	--	--

가 가) (CF) :APEC (1. 가 ..	: BMN : : ; ; ; , ;	가 9 8 3 9 8 : 가 .

4:

: 21		: NEDM : : , , , , , ,	가 98 6 13-14 “ 가 APEC HRDWG APEC 가 98 12

5 ()

	<p>1. :</p> <p>2.</p> <p>3. (CF)</p> <p>4.</p>	<p>: HURDIT</p> <p>:</p> <p>:</p> <p>,</p>	<p>1.1997.5 HRD</p> <p>, 97.7 BAC</p> <p>97.12</p> <p>2.98 가</p> <p>3. ,</p> <p>4.98.10</p> <p>5.</p>
(CF)	<p>1.</p> <p>2. , , 3</p> <p>3.</p>	<p>: EDFOR</p> <p>:</p> <p>:</p> <p>,</p> <p>,</p>	<p>1.1997.5 HRD</p> <p>, 97.7. BAC</p> <p>2.98.1</p>

6.

<p>(SF)</p>	<p>APEC (, 2 , 2)</p>	<p>: EDFOR : : , , , , 가 , ,</p>	<p>3 18 HRDWG 1998 6 99 4 5 가 99 9 APEC , 99 8 9 2 가 0 0 2 0</p>
	<p>APEC</p>	<p>: HURDIT : :</p>	<p>98 4 “ 가 98 2</p>

(S F)	,	: LMI	3
	가 .	:	.
		:	
APEC (SF)	1. 2-3 APEC	; NEDM	1 1997. 6
		:	2.1997 50
		:	가. 1998 11
		,	
		,	
		,	

7.

<p>(S F) , 1</p>	<p>가</p>	<p>: NEDM : : , , , , , , , , ,</p>	<p>1 . 가 가 , , 가 2 . . 1999 3 . 가 가 1998 가 1999 가 .</p>

7 ()

- (CF)	1. - 2.	: NEDM : : , , , , , , , , , , ,	1.1997.5 HRD , 97.7. BAC . 1 98.7
가 (TILF)	1. 가 2. 가 3. (GTAP)	: NEDM : : , , , , , 가 ,	1997.5 TILF . 97.7. BAC

7 . ()

<p>: HRD (CF)</p>	<p>APEC 97 11</p>	<p>: NEDM : : APEC</p>	<p>18 HRDWG BAC 98 6 가 1 가 99 4 가 99 5 HRDWG 98 HRD</p>
-------------------	-------------------	--------------------------------	--

8.

APEC HRD (SF)		: HURDIT : :	28-29 HRDWG 97 16 가 APEC

APEC (SF)	UMAP	: LEADER 'S PRIORITIES : :	
APEC (SF)	APEC APEC 가 APEC	: LEADER 'S PRIORITIES : : , , , , , , , , , , , 가 , ,	1997 5 APEC . mission statement . APEC ,

<p>APEC (ACTETSME) (SF)</p>	<p>:</p> <p>:</p>	<p>: NEDM</p> <p>: PHILIPPINES</p> <p>:</p>	<p>ACTETSME ,</p> <p>/</p> <p>: (a)</p> <p>: 1997. 3. 17-21; (b)</p> <p>: 1997. 4. 16-30; (c) APEC</p> <p>: 1997. 6. 18-20; (d)</p> <p>APEC</p> <p>: 1997. 8. 20-22; (e)</p> <p>: 1997. 10. 23-25.</p>
<p>(SF)</p>	<p>,</p> <p>,</p>	<p>: EDFOR</p> <p>: KOREA</p> <p>: , , ,</p>	<p>1995 가</p> <p>, 1</p> <p>1</p> <p>1997 3</p> <p>,</p> <p>1</p> <p>3 .</p>

8 ()

<p>APEC (SF)</p>	<p>, APEC , : A) B) C) D) E)</p>	<p>: EDFOR : :</p>	<p>1. 1997 7 AEF 1997 12 5 1 1</p>

(CF)	<p>6</p> <p>“ We are APEC ”</p> <p>가 ,</p> <p>APEC</p>	<p>: EdFor</p> <p>:</p> <p>:</p> <p>,</p> <p>,</p> <p>,</p> <p>,</p> <p>,</p> <p>,</p>	<p>99 12</p> <p>99</p> <p>가 3</p> <p>-APEC 가</p>
(SF)	<p>, OJT OFF-JT</p> <p>가</p>	<p>: NEDM</p> <p>:</p> <p>:</p> <p>,</p> <p>,</p> <p>,</p> <p>,</p>	<p>98 12 1 , , 12</p> <p>4</p>

8 ()

<p>21 (SF)</p>	<p>APEC APEC</p>	<p>: EDFOR : JAPAN 가 : , , , , , ' 가 , , , ,</p>	<p>APEC 1995 9 " 21 : APEC " 2 1997 3 가 99 .</p>
<p>(LF)</p>	<p>1.</p>	<p>: BMN/ NEDM : 가 : , , , , , , , , , ,</p>	<p>12 APEC 가 160 , , , 97 . 98 .</p>

98(LF)	1.	: BMN : 가 : , , , , , , , , , , 가 , .	97 5 HR DW G 97 7 TILF B A C WG 2 99 . 가 98 .

8. ()

(UMAP) (SF)	,	<p>: EDFOR</p> <p>:</p> <p>: , , ,</p> <p>, , ,</p>	<p>UMAP 7</p> <p>가 1999 9</p> <p>.</p> <p>(UCTS) . UMAP</p> <p>(, 2001/ 2002). 8</p> <p>2000 9</p> <p>.</p> <p>1999 10</p> <p>5 .</p>

APEC

2000

(HRDWG)

2000 1

HRDWG 11 “ ”
“ HRD 94
” “ ”
97 1 , HRDWG가 8
99 APEC HRD 21
HRDWG
APEC APEC HRD 2000
APEC 가
HRD APEC
APEC
HRDWG가

2000

APEC

HRDWG

HRDWG

1. APEC

APEC
APEC ECOTEC

2. APEC HRD (3 HRD)

APEC
APEC
APEC

(4) HRDWG

2000

APEC
HRDWG

가

4 APEC HRD
APEC

97 1

8

APEC
3 HRD

가

가

가,

가

가

가

가

가
가 가 HRDWG
“ ”, “ HRDWG ” , APEC
가
가

8

1. .
2. .
,
3. , 가, , .
,
4. .
, , ,
,
5. , , , ,
, . 21 ,
6. .
7. , ,
,
8. .

I.

1.

<p>1 (SF)</p>		<p>: BMN</p>	<p>1. http://www1.sphere.ne.jp/mdl/ 2. 1998. 6. 20 3. 1999. 6</p>
<p>(CF)</p>		<p>: , 가</p>	<p>1 . 2000. 1 -12 2. 2000. 9 3. 2001. 1- 6 (2) 4. 2001. 7- 12</p>

2.

<p>APEC : APEC</p>	<p>APEC APEC APEC APEC APEC APEC 가 APEC</p>	<p>:</p>	<p>1. 2. 가 3. 2000. 1 가 가 4. 2000. 2 - 5 가 5. 2000. 5 6. 2000. 7</p>
------------------------	---	----------	--

3. , 가, , ,
..

HRD (SF)	<p style="text-align: center;">HRD</p> <p>APEC To reveal HRD program and policy preferences of APEC HRD</p> <p>HRD</p> <p>HRD</p>	<p style="text-align: center;">: HURDIT</p> <p>:</p> <p>가 : , , ,</p> <p>, , ,</p>	<p style="text-align: right;">APEC</p> <p>HURDIT</p> <p>..</p> <p style="text-align: right;">98 5</p> <p>18-20</p> <p>..</p>

3A ()

(Total System) APEC (SF)	Management (NIKKEIREN) (NICC)	APEC TMS : BMN/ HURDIT : : , , , , , ,	3 Management System) (Total) APEC 99 10 25 11 9 15 9 가 HRDWG 4 2000
(SF)	가	: BMN : : , , , , , ,	가 가 '97 가

3A ()

<p>(Business Volunteer Program) (SF)</p>	<p>1. APEC 가</p>	<p>LEADER ' S INITIATIVES</p>	<p>: www .apsecsec.org .sg; www .actetsme.org .ph , 9 8 4 B V P 가 가 9 8 8 9 8 1 BVP CO 6 .</p>
---	------------------	-------------------------------	--

(CF)	1 1 APEC : APEC (2) APEC	: HURDIT : ,	2 4 . 2 0 0 0 1 가 2 0 0 1 1 2 ..

3A ()

<p>2000(CF)</p>	<p>APEC 가</p> <p>가 .</p> <p>·</p> <p>' APEC</p> <p>.</p>	<p>: BMN</p> <p>:</p> <p>:</p> <p>' , ' , ' 가</p> <p>' , ' , ' 가</p>	<p>- APEC ADR ADR</p> <p>ADR</p> <p>: 2000 5 - 10</p> <p>-ADR</p> <p>2000 10 - 2001 :</p> <p>2 ? ADR</p> <p>ADR</p> <p>: 2001 11</p> <p>- 2001 8</p>
<p>가 :</p> <p>(SF)</p>		<p>: BMN</p> <p>:</p> <p>: , , i</p>	<p>가</p>

3A ()

			9 7 4 - 9 9 3 :
			6
			9 8 4 - 2 0 0 0 3
			: 3
(SF)	APEC	: HURDIT	9 9 4 - 2 0 0 1
	APEC 가	:	3 : 2
	가	:	2
		:	0 0 0 3 2 8 3
		:	9 .
		:	가
		:	가
		:	0 0 0 4 . 9 9 2
		:	가
		:	가
		:	가

3A ()

<p>APEC (CF)</p>	<p>APEC APEC " APEC " APEC HRD</p>	<p>: BMN : : , 가 , , , , 가 , , ,</p>	<p>2000 1 - 6 : 2000 7 ; 2 2000 8 - 11 : 2000 12 - 200 1 2 : 가 2001 3 : 1 2001 3 - 5 : 2 2001 6 : 2 2001 7 - 10 :</p>
----------------------	--	--	---

3B ()

<p>SMEs APEC</p>	<p>1. APEC SMEs APEC SMEs</p> <p>2. SMEs</p>	<p>: NEDM</p>	<p>1 ACTETSME</p> <p>2.</p> <p>(a) 97 3 17 - 2 1 : SMEs</p> <p>(b) 97 4 16 - 3 0 : 가</p> <p>(c) 97 6 18 - 2 0 : APEC SMEs 가</p> <p>(d) 97 8 20 - 2 2 : APEC SMEs</p> <p>(e) 97 10 23 - 25 :</p>
----------------------	--	---------------	---

2 APEC SMEs ?	- APEC	: HURDIT : :	1. 9 8 9 가 . 가 1 9 .
H R D APEC (SF)	가 H R D ' ..	: HURDIT : : APEC	3 H R D APEC 2 1 1 9 가 38 가 9 9 7 1 3 1 5 4 APEC H R D 2 0 0 0 .

3C:

,

APEC/ PFP (SF)	.	: HURDIT :	9 6 2000 3 ? 2 0 0 0 4) (

<p>APEC 가 (II) (SF)</p>	<p>II ?APECWG</p>	<p>: BMN : USA</p>	<p>97 5 HRDWG 97 7 BA " 가 가 APEC WG 3 가 3 1997 6 W G 가 가 " " 가 97 9 7 ' 1 1 APE C 가</p>
-------------------------------	-----------------------	------------------------	---

3C ()

<p>APEC 가 (MNEs) HRD (CF)</p>	<p>18 APEC 98 11</p> <p>4</p> <p>가</p> <p>* * * *</p>	<p>NEDM : HURDIT , BMN ,</p> <p>:</p> <p>:</p>	<p>2000 1 - 2 :</p> <p>2000 3 - 4 :</p> <p>2000 5 - 7 :</p> <p>2000 8 - 9 :</p> <p>2000 8 - 9 :</p> <p>2000 10 :</p>
---	---	--	--

3C ()

<p>가 (I I APEC) (SF)</p>	<p>가 가 () 가 , 가 , HRD</p>	<p>: BMN : AUSTRALIA : , , , , ,</p>	<p>97 7 - 98 5 : 3 가 APEC 98 : 3 가 가 98 : 가 , , 가 7. 2 0 0 0 :</p>
--------------------------------	--	--	---

: APEC 가 가) (CF) (가 ..	: BMN : : , , ,	8 . 가 98 3 ; 98 10 : 가 " (Resour-s es for the Fut ure) " .

3C ()

<p>APEC (CF)</p>	<p>가 " HRD " : APEC HRD R DWG H : BMN : HR DWG가 9 , ' , 가 , 8 1 1 . 9 9 1 " " WG 가 # 3 "</p>		<p>2 0 0 0 1 : 2 0 0 0 3 : 2 0 0 0 1 2 ; 2 0 0 1 3 : 5. 2 0 0 1 6 : HR DWG</p>
---------------------------	--	--	--

5 ()

(CF)	가 , . 가 .	: 가 :	1. 2000.1 2. 2000.3 3. 2000.4-5 4. 2000.6-7

6.

(SF)	<p>APEC ()</p> <p>2 , 2)</p>	<p>: EDFOR</p> <p>:</p> <p>:</p> <p>, , , , 가 , ,</p>	<p>HRDWG 3 18 1998 6 (i)</p> <p>APEC (ii)</p> <p>APEC ()</p> <p>99 2 1 1</p> <p>2 2 0 0 0 6 0 . 2 0 0 0 1 0</p>

6 ()

(S F)	,	: LMI	3
	가 .	:	.
APEC (SF)	1. 2-3 APEC	; NEDM : : , , , ,	1 1997. 6 2.1997 가. 1998 11 50 3.1998 가. 1999 7 32

8: /

APEC (SF)	UMAP	: LEADER ' S PRIORITIES : :	
APEC (SF)	APEC APEC 가 APEC	: LEADER ' S PRIORITIES : : , , , , , , , , , 가 , ,	1997 5 APEC . mission statement . APEC , .

8 ()

<p>APEC (SF)</p>	<p>, APEC , : A) B) C) D) E)</p>	<p>: EDFOR : :</p>	<p>1. 1997 7 AEF . 7 12 5 1 . 1997 1</p>

8 ()

<p>APEC (ACTETSME) (SF)</p>	<p>:</p> <p>:</p>	<p>: NEDM</p> <p>: PHILIPPINES</p> <p>:</p>	<p>ACTETSME ,</p> <p>/</p> <p>: (a)</p> <p>: 1997. 3. 17-21; (b)</p> <p>: 1997. 4. 16-30; (c) APEC</p> <p>: 1997. 6. 18-20; (d)</p> <p>APEC</p> <p>: 1997. 8. 20-22; (e)</p> <p>: 1997. 10. 24-25.</p>
<p>(SF)</p>	<p>,</p>	<p>: EDFOR</p> <p>: KOREA</p> <p>:</p>	<p>1995 가</p> <p>, 1</p> <p>1</p> <p>1997 3</p> <p>,</p> <p>1</p> <p>3 .</p>

<p>(CF)</p>	<p>6 “ We are APEC ” 가 APEC</p>	<p>: EdFor : : , , , , , , , , , ,</p>	<p>'We are APEC' 2000 1-2</p>
<p>? 2 (SF)</p>	<p>가 : , , , , 가 , , , -</p>	<p>: NEDM : JAPAN : , , , , 가 , , , ,</p>	<p>1 20-21</p>

8 ()

APEC/ PFP 가 (SF)	:	가 : HURDIT :	1996 2000 (2000 3 -2001 4)
APEC/ PFP (SF)	:	: HURDIT :	1996 2000 (2000 3 -2001 4)
21 (SF)	APEC APEC	: EDFOR : JAPAN 가 : , , , , 가 , , , , , 3	APEC 9 : APEC " 21 1995 1997 3 2 3 1999

8 ()

(UMAP) (SF)	,	: EDFOR : : , , , , , , , , , ,	UMAP 7 가 1999 9 · (UCTS) . UMAP (, 2001/ 2002). 8 2000 9 · 1999 10 5 .

8 ()

(CF)	TPM TPM , TPM TPM ,	: : : , , ' , ' 가 , ,	

8 ()

APEC	APEC	: EDFOR : 가 가 :	1998 6 18 HRD WG 1998/ 99 7 APEC 가 (NUS) , (NTU) . 2000/ 2001 7 APEC 8 45,000 1 가 가 . KDI , APEC APEC .

C

APEC (Guidebook on APEC Projects)

C APEC 2000 8 APEC
4 (APEC Secretariat, *Guidebook on APEC Projects*, 4th ed., 2000)
. APEC APEC , , 가
,
. 1 2 ,
(Annex) . , Annex E
. 가 ,
.

APEC

1 :

2 : 가

APEC

2000 8 , 4

A	APEC	..	32
		34
	Ecotech Weightings Matrix	36
	APEC	38
	가	43
A1	APEC	*	45
A2	APEC TILF	*	46
B	APEC 가	48
B1	APEC Ecotech	53
	TILF : 가	57
	TILF 가	62
D	TILF 가	66
E	APEC	68
E1	APEC	74
E2	APEC	76
E3	78
	APEC Project No: [WG] 05/ 99 “	82
	”	84
F	APEC 가	86
F1	, APEC	91
F2	94
	APEC	96
F3	APEC 가	97
	(Sex-disaggregated Data and Information)	101
G	APEC	103
G1	109

1

1.1 APEC (I)
가 ()

1.2 (quick reference guide)
APEC (Budget and
Management Committee, "BMC," 1998 11 "BAC,"
Budget and Administrative Committee)
("SOMs," Senior Officials Meetings) 가
MBC/ BAC SOMs .

1 :

2

2.1 2000 7 31 , APEC

- (a) APEC
- (b) APEC
- (c) APEC TILF()

2.2 APEC APEC , ,

2.3 APEC APEC

2.4 APEC TILF (Leader' or
Ministers' directives) (Osaka Action Agenda)

. APEC TILF , ,
APEC .

2.5 APEC 1 1 12 31 .

3 APEC

APEC TILF

3.1

(11) APEC

가, APEC TILF APEC	() 4/ 5
APEC 가,	4/ 5
/ Shepherd) APEC (MS Word 6.0)	(Chair/ Lead 6 *
APEC BMC BMC (BMC 가)	BMC APEC (7/ 8 .
SOM BMC가 APEC	9 *
SOM	11 *
APEC	1

	1
TILF APEC APEC TILF 가 ,) 1	4/5
/ 가 , 가	가
	2 (, 2000 HRD 05/ 2000 2001 12 31)

(* : , BMC

, APEC

www.apecsec.or.sg.

가 , BMC
APEC)

3.2 BMC 2/3 7/8 2
3.1 7/8

3.3 BMC 2/3
" "
. 1999 7 BMC
" " , 2000 7
:

(a) APEC

(b)

:

(i) BMC가 7/8

(ii)

3.4 가 가 (TILF) , 가 3.3 .

3.5 US\$20,000 BMC
US\$20,000 BMC
가 .
12 31 (, 2000 3
2001 12 31).

3.6 , BMC TILF
가 BMC가 . 가

APEC

3.7

APEC

TILF

가

,

가

가

4 BMC

TILF

4.1 : A APEC

4.2 : A ,
. 1999 9

Ecotech Weightings Matrix Ecotech (TILF
)
(Working Group/ Committees), /
matrix 가 가 .
BMC
. 1999 7 BMC ,

4.3 :
. 1999 7 BMC ,
BMC

. “ ”(3.3)
가 .

4.4 가 : 가 , ,

4.5 가 (self-funding): 가
가 .

4.6 / :
/
APEC , BMC가 .
/
가
, APEC ,
APEC . 2000
3 BMC .
APEC / .
APEC 가 /
,
APEC .

. / , A
가 “ ”(www.apecsec.org.sg/apec_organization/policy_procedure/database/db99.htm)

4.7 (Hard Copy) : 가
(electronic means)

4.8 15% : APEC
APEC 15% .
2001 US\$200 , APEC

2001 7 BMC 2002 US\$300,000
15% 2000 8
TILF .

4.9 : TILF
, APEC 가 (1
) , 가
.

4.10 :
,
가 , ,
.

4.11 : .
가 , ()
A4 10 .

4.12 가: BMC
APEC (가 ,
가 /) 가 가 가 . APEC
B “APEC 가 ”
가 . APEC B
APEC 가 가 . TILF
: 가 B 가 C “TILF
” . TILF

15 , 1
2

4.13 : 가
가 , APEC

4.14 : APEC 가 BMC
()
. BMC 2000 7

4.15 APEC : ,
(Director) ,
(agent) () /

5

5.1 : 가 ,
APEC . TILF
, BMC가
, (5)
, 가 .

5.2 : APEC
, . (가
가) APEC .
, 가
APEC
E .

5.3 APEC : APEC
APEC APEC
APEC
APEC .

5.4 APEC : APEC
(Directors)() 가
가 /
가
APEC
, ()

(work of trip)

5

. BMC

, BMC

5.5 :

(a)

BMC

가

, APEC

BMC

(b)

가

, BMC

가
)

(가

(c)

가

APEC

가

APEC ,

가

, BMC

5.6 /

(,

)

,

가

5.7 : II .

5.8 : 가
가 .
, , (payment
instructions)() .
.

6

- 6.1 : / 가
() 가 ,
- 6.2 : 11 ,
가 (payment instruction),
(Director)() APEC
- (:
APEC 가
가 APEC .)
- 6.3 : 가 ,
, CD, , 5 (hard copy)
2 (electronic copy) (Director)()
APEC
- 6.4 가 : II . BMC
가 가 ,

7 가

7.1 TILF APEC

(a) :

(b) APEC 가 : APEC 가

(c) : , , 가 , APEC

7.2

7.3 (, , , ' ') . (

7.4)

(a) APEC

(b) US\$20,000 , APEC /

가

(, , , , ,) APEC
(Director)()

(c) US\$20,000 US\$50,000 , APEC /
가 APEC
(Director)() (RFP) ,
RFP 3 . RFP가
. APEC /

APEC
(b) .
. APEC /

(d) US\$50,000 , APEC /
가 APEC (Director)(
) RFP RFP
. APEC /
가

7.4

(a) 1999 7 BMC

1. 가 .
2. clr 가 ,
BMC 가 . BMC
가
가 .
3. (, ,)
/ / 가
(a) 가 , 가
(b) , BMC가 ,
가 . 가
BMC
, 5
, BMC .
(i) 가 가
(ii)
4. 3 .

/ / 가가
/

(b)

5

APEC

. APEC

5

(c) APEC /

가

4

가

,
가 ,

() 가

가

가

(d)

가

()

,
APEC

, 가

9

9

가 9

, BMC

A 17

가

가

가

가

(e)

UN

(Schedule of Daily Subsistence Allowance Rate)

가

60%

가

100%가

(

APEC

, APEC

가

)

가

60%

, APEC

(

)

40%

가

(Director)()

APEC

가

()

(on a need basis)

(f) 1 “ 가 ” , “ ”
가 ,
25% 가
25% “ 가 ”

7.5

(a) , .

(b) APEC .

(c) APEC APEC

(d) ,

7.6

(a) .

(b) , 가 / .

7.7

(a) 가 .
 , 가 APEC .

(b) ,
 가 .

(i) — , , ,
 , — / 가 .

(ii)

(iii) — 가

(iv)

(v) , APEC (Publication Policy)

가 .

8 TILF

8.1 : TILF , 가
· ,

(a) , ,

(b) , ,

(c) APEC 가

8.2 : 7 TILF
·

8.3 가 : TILF 가 가 .
TILF 가
D .

8.4 , BMC TILF
·

(a)

1. 1996	TILF	,	
1998	1999	, BMC	
		TILF	BMC

2. TILF

, BMC TILF 가

3. (, ,) 가
/ / 가

(a) , 가

(b) , BMC가
가
가 BMC

, 5
, BMC

(i) 가 가

(ii)

4. ()

(a) ,

(b) ,

. BMC가
 , 가
 , BMC
 , 5
 , BMC
 .
 (i) 가
 (ii)
 5. 3 4
 TILF

/ / 가가
 / /

(b) — (9)

(c) — 가

(d) —

(e) (optional) —

(f) — 가

. (,)
.
8.5 2000 3 BMC TILF .
C D .

9

9.1 : APEC , 가
,
(A) 16
, APEC
, / 가

9.2 : 3.7 , APEC
(9.1) ,
(, 가
)
, (A) 17

- (a)
- (b)
- (c)
- (d)

9.3 G, ,
,

10

10.1 APEC 가 3

10.2 (, ,) 가 , APEC 가 BMC , BMC

10.3 BMC (Committee Chair/ Lead Shepherd) , / 가 BMC APEC , 1

11

11.1 가 .

11.2 가 .

(a) 가

. (5.8)

(b) / , 가 ,

, 가

.

(c)

US\$2,000 ,

/ APEC

, /

3 .

(d)

US\$2,000 ,

, 가

, 가

APEC .

(e)

(f) (,)

(g) 3 가

11.3 11.2 ,

(a)

(b) 가 , , ,
(가), , 가
APEC
가 US\$2,000

11.2 (c) (d)

(c) ()
APEC 가

(, CD-ROM,) 5 (hard

copies) 1 (electronic copy)(가)
(Director)() APEC .

(d)

APEC 가

11.4 11.2 11.3 TILF .
TILF , ,

가

, APEC .

11.5 APEC 가

,

5

, 가 BMC .

II 가

12 APEC 가

12.1 APEC 가 1998 9

SOM , 1999 7 BMC가 F .

12.2 1999 7 , BMC APEC

가 7 (7 Small Group) .

가 1999 8 SOM

, 2000 1 1

, BMC .

4 2000 8 APEC .

APEC

TILF

APEC

1.

2. Ecotech Weightings Matrix

Ecotech

Ecotech

가

,

/

(Lead Shepherd/ Chair)

(Remark Box)

TILF

,

"Not applicable - TILF project"

3. APEC

4.

가

5.

TILF

가

() 가
APEC .
(The Budget and Management
Committee) .

()
 APEC 가

()
 【 】 TILF

: ()	:	/
/ :		
:		
APEC :		
APEC ():		
: , (M/F)		
:	Tel: Fax: Email:	
	(US\$):	APEC (US\$):

: /	
:	:
:	
:	
(email	가) :
/WG	(가)
(email	가) :

Ecotech Weightings Matrix

	YES =2 () NO =0
/ #	
Ecotech	
/ 가 *	
/ 가**	
APEC TILF ,	
Ecotech Concept) (Ecotech Common Policy ,	
APEC 가 . ,	
APEC -	

)
3 가
* 가(, , ,)
** 1 , 3

: (TILF 가
. / .)

APEC _____

APEC (Guidebook on APEC Projects)
“ (Guide to Strengthening
Project Management and Performance) 가
APEC www.apecsec.org.sg

가 , B APEC 가
(Criteria of Assessment of APEC project) “APEC 가 ”

가

A. _____

01.

02.

03. 가

(.)
(19 가)

04. APEC ,
(Action Program), ,
APEC (APEC Action Agenda)

05. TILF : 가 APEC
(,)

06. ,
,

07. / 가. / 가
, APEC
(*)

08. , 가 "APEC 가 "(
) 가. (*)

09. 가 APEC
가 .

10. ,

11.

12.

13. (12)

14. APEC (12)

. ()

15.

A1 TILF

A2 가 (,

) 가

16.

APEC

17. APEC

18.

- a.
- b.
- c. (, , ,)
- d.
- e. 가
- f.
 - i)
 - ii)
- g. ,

가

19. 3 , 가

() . ,
가 .

B. / (Working Group/ Committee)

(/ (Working Group/ Committee)) APEC

• APEC SOM
가.

• APEC
가.

• 가 /
, APEC
,
가.

• APEC 가.
가 BMC 가 , /
가 , , .

()

1. , 가
. APEC
(APEC *Framework for the
Integration of Women in APEC*) . ,
(),
/ .

2. 가 .
, , ,
.

3. .

4. (가)
.

5. 가?

• : 가?

가? 가?

6. 가?

7. ,

가

8. / 가 APEC 가
가 , /

APEC

*

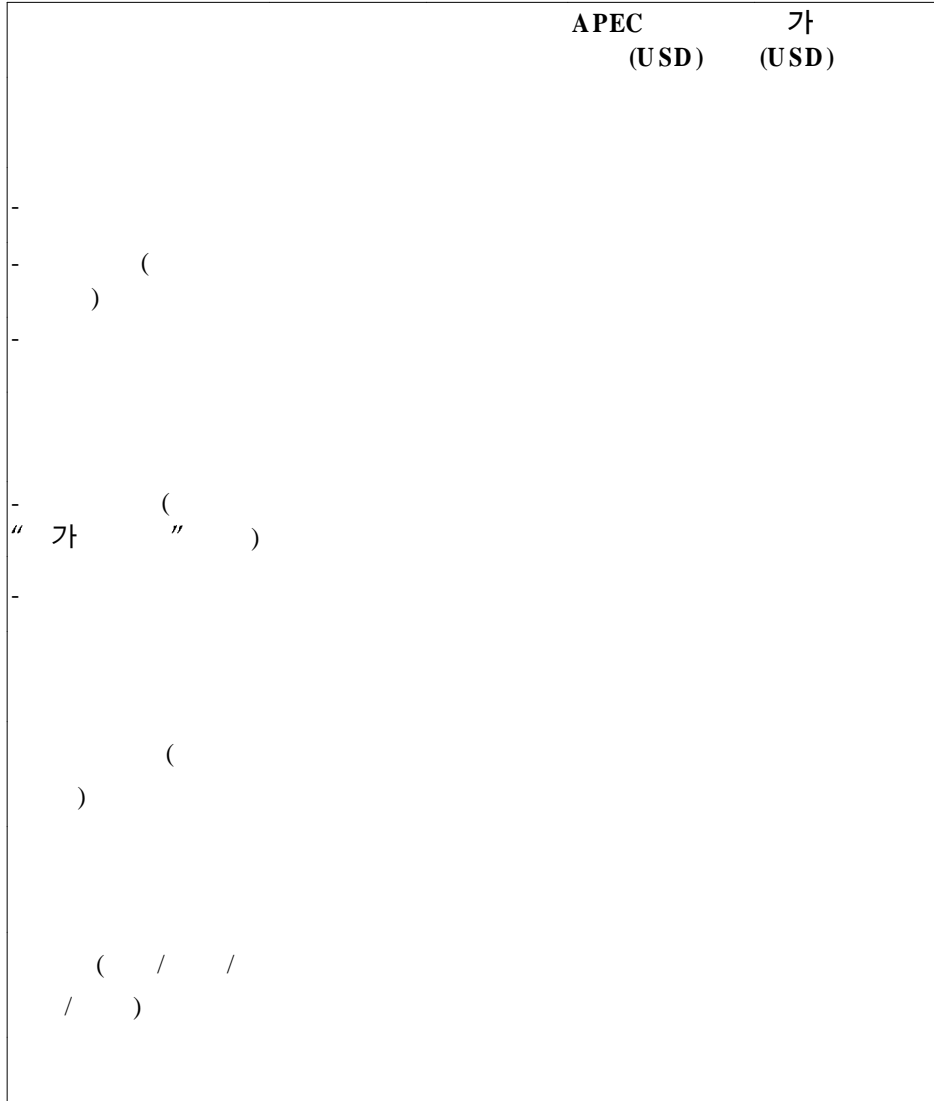

* 가 1 , .

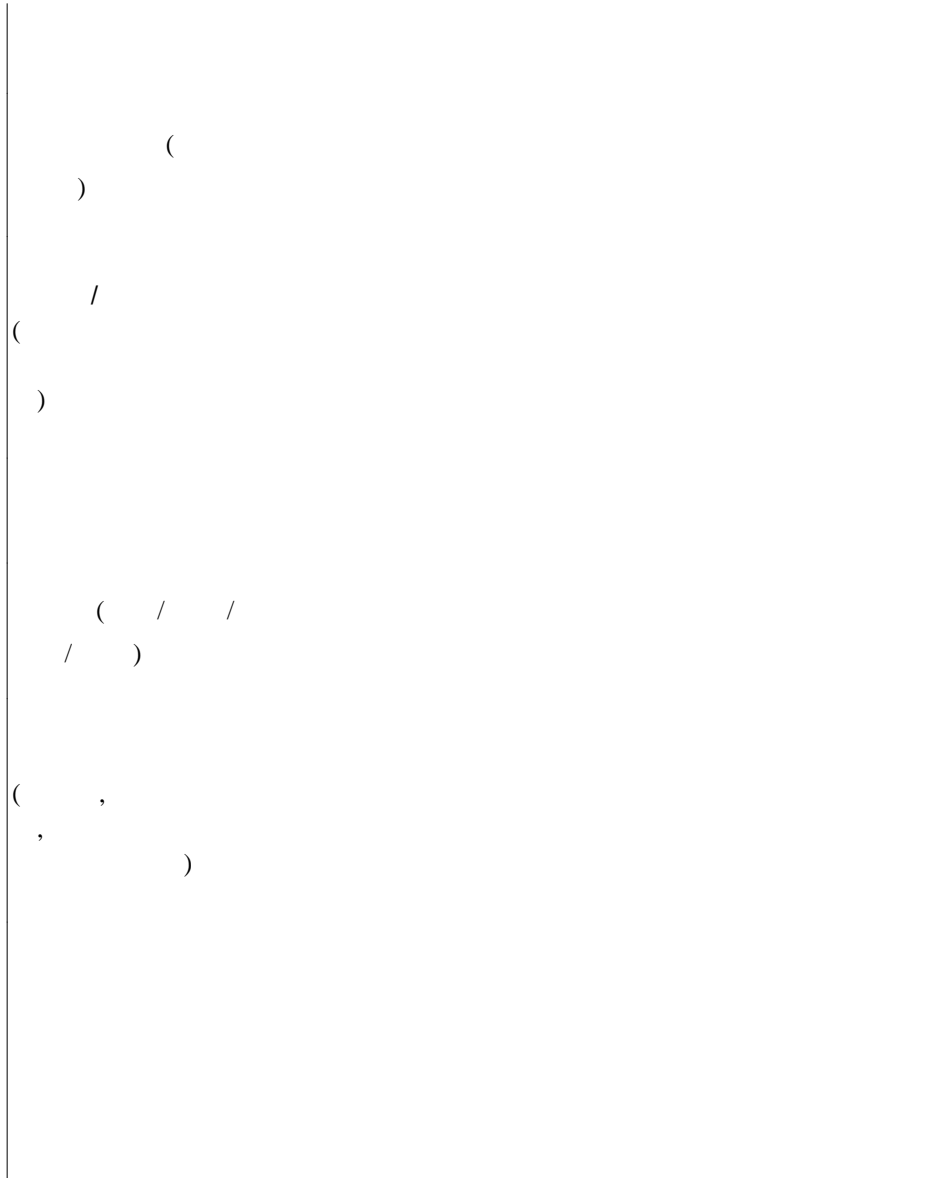

* 가 1

,

.

B

APEC 가
(1995 9 SOM , 2000 7 BMC)

APEC 가 (b) 가 (c) 4가 (a) (d)

" (must)" " (should)" ,
BMC/ SOM

가
" (as appropriate)

A. APEC 가

, APEC
SOM , BMC

APEC

1. , (Bogor Declaration)

2. , , .
3. APEC 가 .
4. / .
5. APEC 가 가 .
6. .
7. (ecotech)
 . '1996 Ecotech '(1996 Manila Declaration on
 Ecotech) 6
 . APEC ,
 (1998 6 SOM APEC Ecotech
 (Guidence on Strengthening
 Management of APEC Ecotech Activities) B1
) 가 .

B.

가 , APEC

1.

2.

3.

4.

(associated output)

5.

6.

7. APEC

8.

APEC

가

9.

D.

1. APEC

SOM

2.

APEC Ecotech
1998 6 18 ,

1. 6 .
 ,
2. ecotech “ ,
 ” ,
(priority-wide framework)
3. .
(, ,) , ,
(ecotech)
IAP , 가
4. ecotech ,
 ,
 . APEC
 . APEC 가

ESC

5. ecotech

,

가

.

가

6. , ecotech

—

—

,

ESC

BMC

7. BMC

APEC

SOM

BMC

8. APEC

BMC

, ecotech

가

9. BMC ,

10.

BMC

BMC

APEC

(Director)(Director)

(13)

APEC

11. APEC ecotech APEC
BMC 가

12. BMC

13. APEC

14. ecotech

Ecotech

15. ecotech 가 , ABAC
ABAC

TILF : 가
(1998 6 SOM , 2000 7 BMC)

APEC ' , ' ,

1.

1994 Bogor APEC 2020 -

“ (Action Agenda) .
 , APEC 가

(Osaka Leaders' Meeting)

APEC 100 .

2.

(a) (eligible project)

“APEC 가
 (Criteria for Assessment of APEC Project)”
 APEC 가) ,
 가 (, 1
 15 , , 2
) APEC 가 .

(b)

(i) , , ,
 가 , (2
 .)

(ii) ,

(iii) APEC
 (,)

(c)

b(i) b(ii) ,
 .

(i) (APEC)

(ii) APEC ()
APEC

(iii) APEC ()
)

b(iii) , 가
. APEC 가 ,

(1) A() B()가
,

(2) , APEC

(3) , *
가

* " " Brunei Darussalam, , , ,
, , 가 , , , , ,
" " APEC
" " ,
APEC 가 .

(d) 가 ()

(i) , , ,

- (,)
- ()
- ()
- (,)
- ()
- ()
- ,

(ii) ,

-
- , (,)
- ()
- ()
- ,

(iii)

- ()

* 가 /
 “APEC 가 ”(Allowable
 expenses under the Operational Account of the APEC Central Fund)

* 가
 , APEC

(e)

- APEC

• BMC (Working Group) (Committees) APEC 가,

• BMC
• SOM BMC ,

• APEC
•
• APEC
• WG/ BMC
: BMC

* , BMC

* APEC ,

* ()

* APEC

* TILF

* BMC (TILF) , 가 ,

TILF

가

1.

- (1) , , ,
•
• ,
• ()

- (2) ,
•
• ,
• ()

: 가 , 가 .

2.

- (1) , , ,
• (,)
()

- (2) ,
• ()
• , /
()(,)

)

(3) APEC

- (1) (2) TILF
()

: 가 , , 가 .
, 가 .

3.

- (1) , , ,
 • : (,) ,
 9) ,
 ,
 • : ()

- (2) ,
 • : (, 9) , ,
 : 가 가 ,
 가 .

4.

a.

(1) , , ,
•
()

(2) ,
•
()

: 가 ,
가 .

b.

(1) , , ,
• , ,

(2) ,
• , ,

: 가 ,
가 .

c.

(1) , , ,
•
• (, ,)

)

(2) ,

•
)

(

,

,

(3)

D

TILF 가

TILF 가

. TILF

	A. , , ,	B. ,	C. APEC
	[REDACTED] [REDACTED] [REDACTED] ()	[REDACTED] ()	
	[REDACTED] (,) [REDACTED] ()	[REDACTED] () [REDACTED] , / ()) (,) [REDACTED])	A B TILF [REDACTED] ()

*

	A. , ,	B. ,	C. APEC
	: (, 9) , '9 , : ()	: () , ,	
	()	' ()	
	,	, ,	
	()	()	

*

APEC

1. BMC가
 ,
 .
 2. APEC
 , APEC ,
 , nomenclature ,
 .
 3. APEC , APEC (Director)(
) 가
 . (Director)()
 , () (Director) (
 Public Affairs) (Director) .
- APEC
4. 가 SOM BMC ,
 APEC () (Director)
 (Director)()

5.

(Director)()

6.

, , 가 ,

7.

Committee)

가

(Steering

8.

/

가

가

9.

()

. (26

)

10.

/

가

. (E1)

11. BMC가 , 가
(,)
 / (E2)
 ,
BMC가
 .

12.

13. APEC .

14. ,
(E3) (Director)()가
 .
US\$20,000 , 가가 .

15. ,
 , 가 ,
E4 . ,
 , ,
(Director)()

16.

,

17. BMC

18. BMC가

19. ()
).

20. APEC 4
(Director)()

21.

22.

23. APEC (Guidebook on APEC Projects) 2

24. BMC

가

25.

APEC

가

. APEC
, BMC

가

26.

27.

가

WG)

28. / BMC가

가

29. APEC (Director)()

. [(65)276-1775], [(65)276-1880]

, 가

[info@mail.apecsec.org.sg] 가 .

APEC

2000 8

Annex E1

APEC

Event	Dates
1. (Steering Committee)	1999 1 20
2. (RFP) APEC	1999 1 25-30
3. APEC RFP	1999 1 31
4.	1999 3 1
5.	1999 3 10-20
6.	
APEC	1999 3 21-30
7. APEC	1999 4 10
8.	1999 4 10
9. , APEC가	
	1999 4 10
10. 1999 5 20 #1 가	1999 5 20
11.	1999 5 25

12.	1999	6	30	#2	가	1999	6	30
13.	1999	7	17	#3	가	1999	7	17
14.						1999	8	15-18
15.								
						1999	8	20
16.						1999	9	2-20

APEC

Annex E2

APEC

()

BMC

(US\$)

(US\$)

\$500

\$900

(4 x \$125)

(9x\$100)

\$28,000

\$28,000

\$3,000

\$5,100*

\$2,600

\$1,790*

\$8,000

가

\$1,000

\$1,000

43,100

36,790

*

Mr AAA	\$1,000 (X Y,)	4x \$80 (Hotel X) =\$320	4x \$60 + 0.25 (40+80)=\$270
Mr BBB	\$2,100 (K Y,)	4x \$80 (Hotel X)= \$320	4x \$60 + 0.25 (100+80)=\$285
Mr CCC	\$2,000 (P Y,)	4x \$80 (Hotel X)=\$320	4x \$60 + 0.25 (60+80)=\$275

Annex E3

[No.]

[]

The Asia-Pacific Economic Cooperation Secretariat (the "APEC Secretariat"),

: 438 Alexandra Road, #14-01/ 04 Alexandra Point, Singapore 119958.

[/] (“ ”),

:

APEC 가

A) *US\$20,000*

A

1)

B

2)

1) E5

2) E6

B) US\$20,000

A RFP³⁾, B 가
[, ,
],

:

1. ,
가 , APEC
US\$[] (United States Dollars [D)

1 } US\$ _____

2 } [] US\$ _____

3 } US\$ _____

2. ,
APEC (Guidebook on
APEC Projects) APEC , APEC

3. 2 APEC .
,

3) RFP E7 .

a) No.

b)

c)

d)

e)

f)

g) , , , , ,

h) 가 , , 가
[]

4. APEC ,

5. 가 [] / []

6. 가
가

APEC

APEC

_____ []

Executive Director/Deputy Executive Director

_____ []

Director (Finance)

[]

_____ ()

_____ ()

Annex E4

APEC Project No: [WG] 05/99 “ ”

가 : Mr AAA
fellow
BBB

- Z
- [WG]
- APEC MRA APEC ,
- APEC ,
- (Equipment Certification ad hoc group)
- [WG] ([] Mr BBB)
(Word 6)

• , APEC []
· , ,
·

· 가
· , APEC

· 가 , (a)
(b) 가 [가/
] APEC 5

1. _____

• 가 가

• 9

• APEC

2. _____

(a) _____ 60% _____

• (가
) 100% (US\$xx). 가
US\$xx x () = US\$yy.
;

• “ 가 ” - 25% x [가
(US\$zz) +
(US\$xx)].

(b) _____ 60% _____

• () xx
(가)

-) (가
40% (US\$xx). 가
40% x (US\$xx) x () =
US\$yy. ;
- , “ 가 ” - 25% x [가
(US\$zz) +
(US\$xx)].

3. _____

- () .
- i. 가
- ii.
- iii. (가)
- iv.
- v. ()

APEC 가
(1998 9 SOM , 2000 BMC)

/

1. , (APEC
가)
가 , APEC

2. APEC . APEC (RFP)
APEC

3. 가 , ,
F1 가 가

4. (F2). BMC
BMC

/

. / APEC BMC 가

/ 가

5. 가 , 가
가 (6) (F3). 가
() 가

6. CTI APEC
가 가
가 ,
, BMC
/ .

7. 1 , 가 ,
가 , 가
CTI06/ 97, CTI07/ 98, CTI08/ 99
가 CTI06/ 97,
CTI07/ 98, CTI08/ 99가 , .

8. APEC 가

가 , 가 , 가 ,
가 .

가 가 .

2 가
, , 가 , () .

가 4
, () ,
가 , / .

/ 가
2 , () 가 ,
APEC BMC .

9. APEC 가 , ,
가 BMC

가

10. BMC 가 가 가
BMC , BMC , APEC
가

APEC 가 가 (2000 1
1)

11. BMC (, ,)
, BMC BMC

12. BMC BMC ,
(, , /
)

13. , BMC
SOM

14. , BMC
, 가 BMC가
,

APEC
2000 8

APEC

: _____

: _____

가 APEC 가

.

,
가 ,

Part A

Part B

.

:

, 가

.

Part A.

()

: _____ : M / F

/ : _____

: _____

(a) 가

?

/

: _____
: _____ : _____

- (b) , , ?
- (c) 가 ?
/ ?
- (d) 가 ?
- (e) 가 ?
- (f) :

Part B 가 (가)

: _____ : M / F
/ : _____
: _____

- (a) ?
- (b) , , 가 ?
- (c) , ,
?
- (d) 가 ?
?

(e)

가 ?

(f)

가

[5]	[4]	[3]	[2]	[1]
()				()
_____	_____	_____	_____	_____

(a)

가 ?

(b)

:()

(c)

가

.

?

()
APEC 가

()
【 】 【 】 TILF

: ()	:	/
/ :		
:		
APEC :		
APEC ():		
: , (M/F)		
:	Tel: Fax: Email:	
	(US\$):	APEC (US\$):

: /	
:	:
:	
:	
(email	가) :
/WG	(가)
(email	가) :

APEC _____

/
: (/) (/)
3 (19) 가 () 가?
, , , , 가 , ,
가 가?
:

: -

BMC

- .
- , "N.A."
- .

APEC 가

1. 가? 가? 가? / 가?
2. 가 3 (19) , 가 가 가?
3. 가?
4. Ecotech - (Manila Framework for Strengthening Economic Cooperation and Development) Ecotech 가?
5. APEC (Framework for the Integration of Women in APEC) 가?
 - : 가? 가? 가?

가?

6.

.

•

:

가

/ (,)

가?

(,)

가?

가?

7.

/

(,

,),

/

(, , , , ,)

) .

8. ()

APEC

가?

APEC

가?

가?

9.

가? /

가? /

10. , , 가 , ,

11. , 가? 가?

12. (, 가). 가 가 가? 가

13. .

14. , .

15. 가 .

16. 가(, , , ,)?

17.

가 가?
3 (19)
, , 가
가?

Comments

18. (Small Group):

19. / (Lead Shepherds/ Chairs):

19. (Secretariat)

(Sex-disaggregated Data and Information)

(Development of mathematics curriculum)

:

1. 가 가 가
가?
2. 가 가 가?
3. 가?
4. 가?

(Community development project)

:

1. 가?
2. 가?
3. 가 가?
4. 가? (,
,
가 가?)

/ (Workshop/ training)

1. 가 가 , 가?

		/	

2. 가?

3. / 가?

4. 가 , 가?

(1997 5 SOM APEC)

—

APEC , , , ,
APEC

—

APEC (advance payment) ,
APEC APEC

, APEC

, , , .

" " APEC

APEC , , ,

1. , BAC ,

BAC .

2. APEC .

3. • ,

• ;
(settlement)

4. APEC
(collection action)

5. (Executive Director)가 APEC (Director) APEC
(submission)
APEC .

6. \$20,000가 ,
(funancial viability)

,
APEC
(official department)

7. (cash flow)
가 APEC

8.

:
APEC

part

APEC
()

1.

(a)

, , 가 ,
, 가 , ,

(b) 25% .

50% .

part

(authority) .

1. 가 3, 4 APEC (practice) .

2. APEC () APEC ,

가 . ,

3. (expenses) 가 , /

4. TILF ,

:

(a)

- - (가
, 9
) ,
G1 .
- - ,
()
- - , ,
.
- -

(b) TILF

- - (A) , , (B) ,
(C) A B TILF
().
,
/ ()
- - , , (가
, 9
) , .
- - , , ,

()

• - , ,
.

• - , , ()
, ,)

5. APEC ()

,
.
.

6. APEC

. , current progress claims
가 . , .

7. () ,

APEC

, APEC

.

8. () , 가 APEC

.

9. APEC 1998 3 BAC

BAC

.

(Designation)

Fax No.

.....

No.()

..... e-mail

가) “ APEC ”(APEC Guidelines on the Policy of Advance Payment) , APEC (no.) US\$......

, :

(a)

(b) 가

1

(c)

, , APEC

APEC

(d)

, APEC

APEC

가

.....가

• []

• 가

가

,

,

(

,

)

.

,

.

APEC

()

.....

: _____

D

21

D < > 가
2000 9 .
, 가 .

1	가	/	1
2		/	23
3		/	·	53
4		/	75
5		/	103
6		/	123
7		/	143
8		/	161
9		/	181
			207

1 가

1.

가. 가 (International Competitiveness)

가 가 1990

- (International Institute for Management Development: IMD¹⁾) , , , , 47

2000 가

• 가 1 , 2 가 , 3 , 4 , 5
 , 6 , 7 , 8 , 9 , 10

- 가 가

< 1-1> 가 8

					SOC			
1995	3	1	1	4	29	4	7	5
1996	3	1	1	3	33	4	12	8
1997	3	2	1	6	11	1	8	5
1998	2	2	1	10	15	2	9	1
1999	18	2	1	9	13	4	12	4
2000	8	2	1	11	13	5	9	5

가 가 , ,
 ,

1) IMD

, 가 , . IMD 8
 (, , , , ,) 293
 가 47 ,

가 가 가 IMD 가

가 1997 가 가 가

-

.

가 21 가

1998 8 'Manpower 21'

- 가 HRD , (MoM)

'Manpower 21' HRD

- 가 가 'Manpower 21' (A

New Manpower Paradigm) . ,

.

.

가 가 가

2)

- 가 21 가

2) 가 가 6 8 .

6 , 가

가 가

. 8 , (two engines)

(external wing)

가 (world class)

. .

가

- (Ministry of Manpower) (1998)
- 'Manpower 21' 가 가 (Talent Capital) ,
 - 가 (hub) ()
 - 가 가 (difference)
- (EDB) (Strategic Economic Plan)
- 1990
- 가 2030 (91 10)
- (EDB) 'Industry 21'
 - 1998 6 'Industry 21' 가 가 (Knowledge-driven) (Leading Competence Center)
 - 'I21' ' 가 hub()
 - 가 , (Innovation), (Capabilities) (KBE) 가
 - 가 Global Hub (world-class capabilities)
 - 가 가 (KDA) (Leading Center)가 , (Headquarter) 가 'I21'
- 'I21' 가
 -

- 가 (risk-taking)
- , 가 .
- 가
- , , () 가
- 가 ,
- 가가
- 가
-
- ,
- ()
- 가
- 'I21' (knowledge-driven manufacturing)
- (knowledge-driven exportable services)
- 가 GDP 40% ,
- 20,000 25,000 .
- 2/3 , 4 3
- 10 'SME 21'
- 'I21'
- SME 21 2000 1 5
- 가 10 90%
- , 가가 1/3
- 가 가 , 35 (governmental institutions) 가

- 가
- SME 21
 - 가
 - 8 3 2
 - 10 1 28,000
 - 56,000 가
 - cleaning 10 가

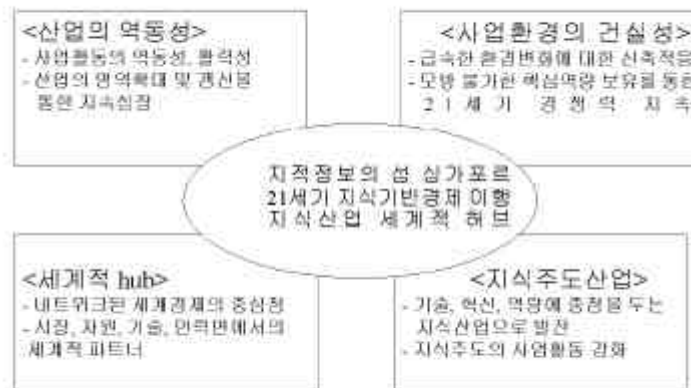

[1-1] 'I21'

3. (performing core strategy)

가.

Singapore 21

- 21 가 가
- 가 가
- 가 ,

• 가 ,
 • 가 , , ,
 - 가
 • 가 21
 • 가
 • 가 ,
 • 가 , 가
 가 가 ,
 가
 - 가 ,
 • 가 ,
 • 가 ,
 - 가 ,
 • 가 가 가
 • 가
 • 가 , 가
 • 가 , 가
 - 21 , 가

- (MoM) 'Manpower 21'
- 'Manpower 21' (holistic approach)
 - , 가 (manpower value chain) , (manpower planning), (lifelong learning), (talent augmentation), (manpower development), (workplace transformation) 6
- (Integrated Manpower Planning)
 - 가 (IMP) (Enhanced Manpower Information system)
 - . . .
 - 가 가 . 가 (National Manpower Council)
- - 가 'Manpower 21' (MDAS, Manpower Development Assistance Scheme)
 - MDAS (School of Lifelong Learning)
 - 1997 (SRP) 가 (NSRS, National Skills Recognition System) (Industry Training Centre)
 - MDAS (IT)
 - MDAS . . .
 - 가 (pre-employment qualification) (skill

- competence) ()
- (SLL)
- (Augmenting Our Talent Pool)
- 가 'Contact Singapore'
- 'Contact Singapore' , , D.C., (Perth)
- (Singapore Outreach)
- 가
- MoM 가 가 가 가 가 가 가 가 (가)
- (Transforming the Work Environment)
- 가 MoM (Cleaning), 가
-
- 가 가 21
-
- 가
- MoM EDB / 가 가 () R&D
- (Redefining Partnership)
- 가 ()
- MoM 가 가 (SNEF, Singapore National Employment Federation) 3 가 (National Manpower Summit)

• 가 Labour
Management Partnership Programme

- 'I21'
- EDB 'I21'
• 가 ,
- • ,
- -
- ()
- 'I21' EDB , , , , ,
- , ,
- EDB • .
가 가 (Value chain) 가가
- 8가
- 2030 400 0.4% .
- , 3
• , , (Economic Panel) ,
2-3 SEP
- • , 3 (Growth Triangle)
- ,
- 가
- (Industry Cluster)

- 가 , .
- . 39% ,
- 9%
- (Multi-agency Task Force) ,
- 가 ,
- 가
- “ (Competitiveness Monitoring Group)”
- ,
- . , , , ,
- 가
- 가 home base ,
- 'SME 21'
- (enterprise-level)
- 가
-
-
- mentoring programme
- (sector-level)
- franchise
- grouping
- (industry upgrading and assistance programme)
- (broad-based)
- 가 (entrepreneurship) 가

- investor business angel network angel
- local talent 가
- (SME hub)

1.

(MoM) 1998

"The Ministry of Manpower adopts a Total Systems approach towards manpower planning and development"

- - (Manpower Planning)
 - (Manpower Development)
 - (Manpower Augmentation)
 - , ,
 - (Workplace Environment and Welfare Corporate Support Manpower Planning)

- Contact Singapore
 - pool
 - 가 가 (SNEF, Singapore National Employment Federation)
 - 가 (National Manpower Summit)
- one call center(callMoM)
 - (1800-438 5122)
 - (, , , ,)
- 가
 - MoM
 -

- (MoM) 1999 4 31 'Manpower 21'
 - 가 (IMP) (Enhanced Manpower Information System)
 - , 가 가 , 가 (National Manpower Council)
- - 가 'Manpower 21' (MDAS, Manpower Development Assistance Scheme)
 - MDAS (School of Lifelong Learning)
 - MDAS (IT)
- (Augmenting Our Talent Pool)
 - ' 가 'Contact Singapore'
 - 'Contact Singapore' , , DC. (Perth)
- , MoM EDB / 가가 가 () R&D
- MoM 가 가 (SNEF, Singapore National Employment Federation) . 3 가 (National Manpower Summit)
 - 가 Labour Management Partnership Programme
- 가 ' 가 ' 2000 8 27 9 10

2.

- (MTI) (EDB) EDB 1961 가 ,
- EDB ' (Manpower Productivity subcommittee)
- 'I21'
- - 가 2010 10 ,
 - , 가 . , . . .
- 1998 가
 - INSEAD가 2000 MBA 2000 MBA
 - MIT 가 2 ,
 - Institute of Finance
- 'I21' ()

- , 3
- 1-2
- 6 10
- , 6 , 4 5
- , 가가
- , (Polytechnics), (Institute of Technical Training)
- 2 3
- 가

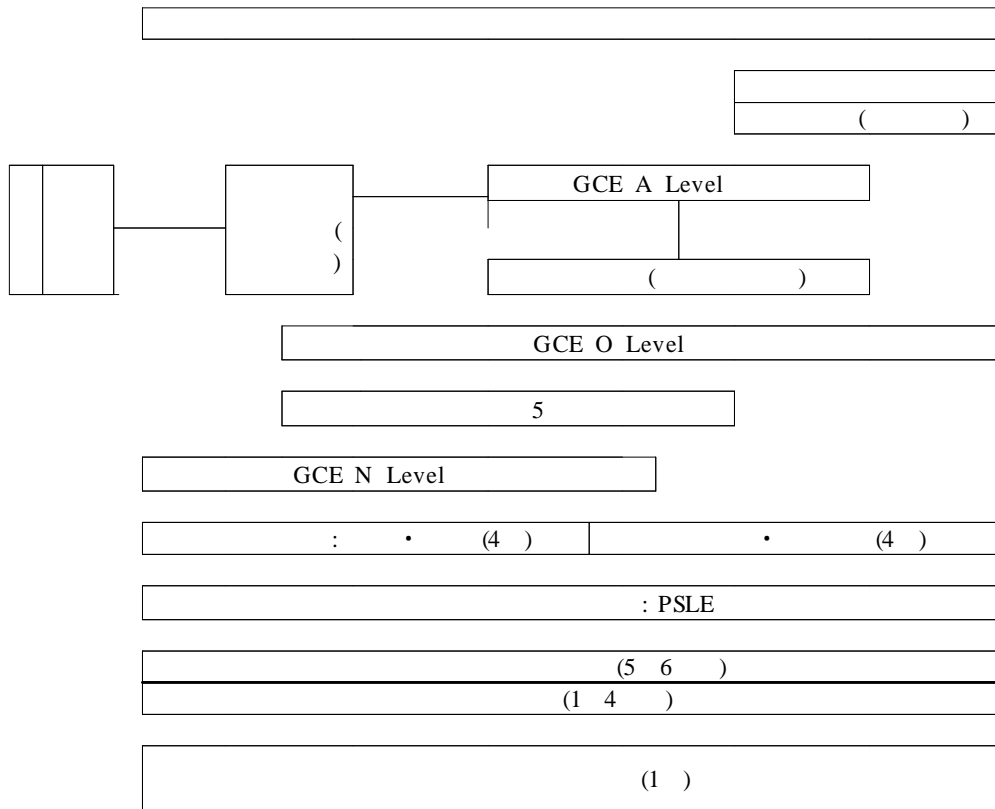

[1-3] 가

. 가

- ,

-
-

2.

가.

- 1 가 (1980 1985)
 -
 - 가
- 2 가 (1986 1991)
 - ' 가 '
- 3 가 : 2000 (1992 1999)
 - 가 one
- 4 가 : Information 21 Master Plan(2000 2010)
 - :
 - : 가
 - , 2005 40 가
 - Interactive Broadband Multimedia
 - LIUP , , 가
 - 4

•



- 1996 (SMP, Specialist Manpower Program)
- 1997 (SRP, Skills Redevelopment Programme)

< 1-2> 가

	12 · 1 , 1 , 2 , CEO/ 8 · , CEO 1	
가	가	
	가 : 가 Pool , , 가	(1)
	가 pools: 가	(18)
	:	(1)
	:	(1)
		(2)
	SDF(Skill Development Fund) EDF(Enterprise Development Fund)	6

< 1-3> 가

	가 , 가	
가	가 6 가 가 가 가	가
	가	가
	People Developer 3	

3.

가. .

가 (NSRS)

가 Labour Management Partnership Programme

가 가 , . (National Manpower Council)

MoM 가 가 (Singapore National Employment Federation) 가 (National Manpower Summit)

. .

1979 (SDF, Skill Development Fund)

- SDF³⁾ 1998 8,800 , 50

(MoM) (income tax)

-

3) SDF 가 (MTI) 1979 , (Skills Development Fund Levy Act) . 同 , 1 가 1 . SDF (Training Grant Scheme) (Training Leave Scheme)

•

가

,

가

가

가

•

가

•

-

(Ministry

of Manpower) ('98), 21('99), IT2000('99)

가

,

-

가 SMP, TAP, IMP, PLE-EDB

•

가

-

가

가 가가

(2000). 21 가 ,

•

, (1999). '99 ,

(1999). 21 가

(2000). 가 가 CSC , KIEP 2000. 5.

(1999). 가 'Industry 21' , KEIP .

(1999). 가 21 , KIEP 1999. 11.

(2000). 가 21 : 'Manpower21'

, KIEP 2000. 2

MoM. Manpower21 ([Http://www.gov.sg/mom/m21](http://www.gov.sg/mom/m21))

Ministry of Manpower of Singapore. 31. Aug 1999. Manpower21

([Http://www.gov.sg/sprinter](http://www.gov.sg/sprinter))

I.

1. HRD

가.

가

HRD

,

HRD

HRD 가

, HRD

((生涯學習)

) (職業能力開發)

HRD 가

- , ,

-

- 가

HRD

,

,

2.

가. 가 : <2000 1 21 >

「21 」

- 가(國), (官), (組織)
가 .

(協治: governance)

.

가

21

-

6

(1996-2000)

, , 가가 가 21

가

3.

가.

, ,
가 .

< >

(省廳) , , , ,
1996 12 「 」

「 」

- 1996 11 가

4가 「

· 「 21 가 「

, 「 」 가

- 1998 2 「 」 「 」

, 2001 1 .

- 「 」 「 」

, , .

- 가 . 「

「 가

」, 「 」

- 1998 3 「 3 (1998-2000)」

가 ,

- , (秋季)

가
(單位累積加算)

- .

- (1995)가 4

1998 5 「 」

1999

- 가

14

- 1980 10 1998 7

< >

21

1997 「 」

<

>

1996 12 「

」

「

」 1997 5

15

,

.

,

.

-

-

「

」(1998 6) 「

」

(1998 4)

.

(都道府縣)

,

가

都道府縣

- 가가 ,

,

,

,

-

,

- ,

- ,
- 가가

-
-
-
-
-

- 가
- 가 가
- 가,
- , 가

-
-
-

- ,
- 「 」
- APEC(.) , APSDEP(.)
-)

- 「 」 「 」

-

,

.

: , ,

: , , ,

: , , , ,

: ,

: , , , ,

: (), 가

2.

(Ministry of Education, Science,
Sports, and Culture) (Ministry of Labour) ,
(International Trade and Industry)

- .
- , , , ,

- .
- .

- , , 가

가

가

가

(Makino, 1997).

가

가

가

(, 1998).

3.

가.

가

가

‘IT(Information Technology)

가

‘IT

IT

IT

가

IT

IT

가

75%

(, 2000).

-

,

가

.

-

가 가

가

-

가

-

가

가

,

.

-

,

.

-

「

」

-

,

,

.

.

,

,

.

. . .

가 ,

, . .

generalist specialist

가

3

, , 3 ' (가)」

1998 「

」 , ,

() ,

(. .)

([8-1]).

- (1996 7)

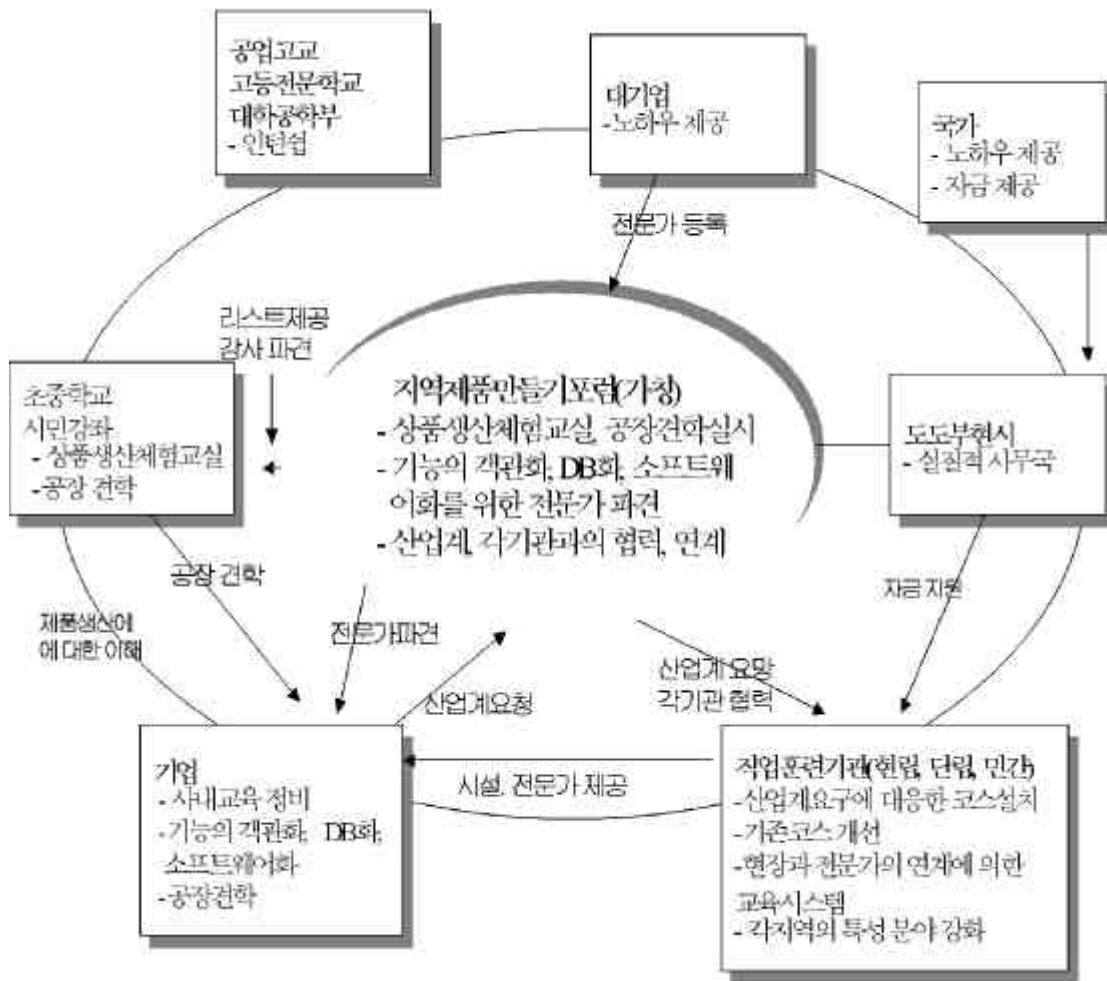

: (1998), 「 가 . 」.

[2-1]

가

가

가

(1997 5)

가

가

가.

: (인)

- , 1

- .

1999

- .
1998

- , 1997

- 1997

- ,
1998

- 2003 5

- ,

- ,

- ,

- ,

-

-

-

1997

.

-

(admission office)

-

,

.

-

,

.

-

-

,

,

,

.

.

-

-

가

-

.

-

.

,

가

1998

가

- 가

가

-

-

PTA

,

가

-

-

-

-

-

,

,

.

,

,

가

2.

,

.

가.

가 .

, , ,

, .

- 가 ' . '

- 가

' ' . 가 가

- ' , ' , ' '

- . . 「 ' 」

- , ,

- , 4

- 가 . 가

, .

< 2-1>

	, ,	
	, (, ,),	, , , , , , , ,
	()	, ()
	.	, , , ,
	.	.
	가 가 .	. 가

: (1998). . :
, 58.

- ,
.
.
.
가)
, 4 가)
가 .
5 1962
, ' ' '
' .
.

가
가

가

가, 가,
가

가

가

가, 가, 가, 가

가, 가

가

가

가

< 2-2>

(1995)

	,		240	161,300
			26	13,200
			3	
			65	218,100
		가	13 6	3,530
			1	-
			354	397,000
			1,421	190,000
			77	
.	ADDS()			
	()			

: 勞働省(1996). 職業能力開發基本計劃. 47-49 .

1997

(勞働省職業能力開發局 能力開發課, 1998: 16-7)

, . , .

.

, 가

(< 8-3>).

- 가 가가

< 2-3 >

가	가 ()		가
	(公益法人) 가	(,) ,	
가 ,	(公益法人) 가	(,) ,	가
, 가	가 가	가 , 가	, 가
,	.	가	.
, 가 .	. , .	, , 25 109	, . , . ,
,	「 」	「 가 」	.
가		() ()	.

: 勞働省(1996). 職業能力開發基本計劃. 53 .

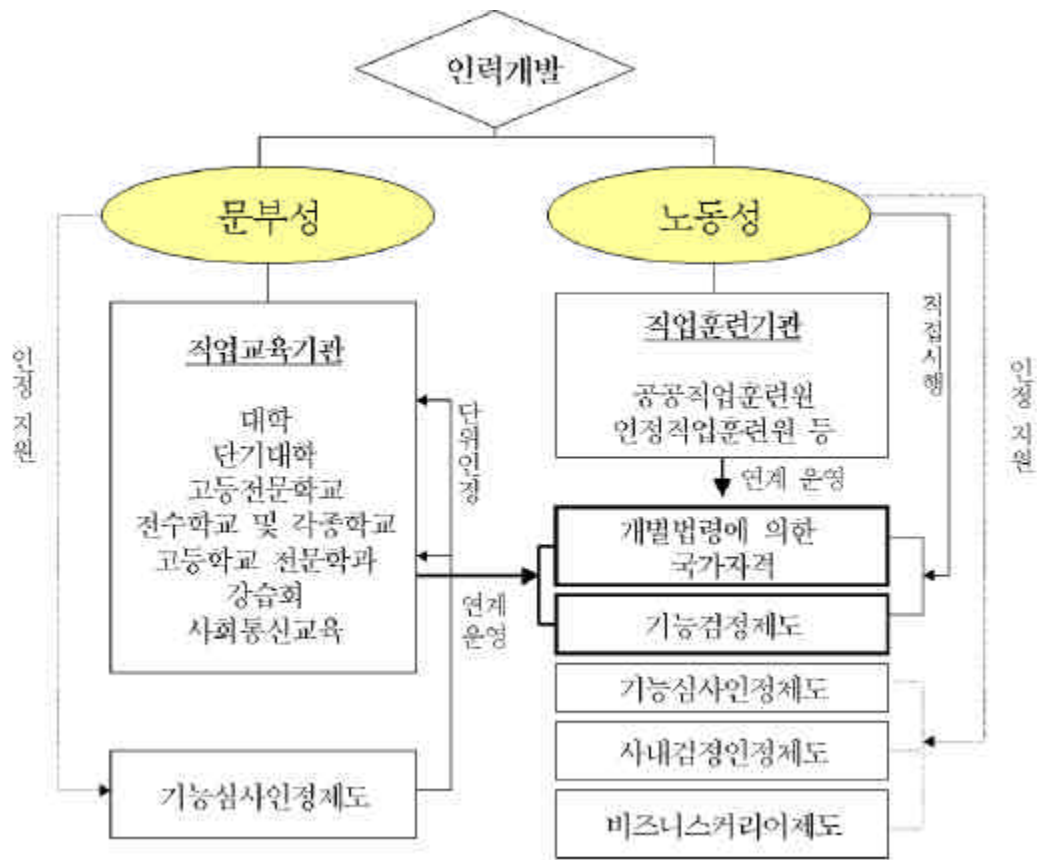

(1998), , 97.

[2-2]

가

가

-

,

,

가 .

3.

가.

21

2001

「 」 가 가 .

,

- 2002

5

-

1998

1999

-

1999

-

-

-

-

‘ ‘ ‘ , ‘

가

,
.
- , , , , ,
 , , , ,
.

-
-
-
-
-
-
-
-
-
-
-
-

•

가

-
-

•

가

IV.

21

가 .

가

가 .

가

가 .

가

가
가 ,

가
가 ,

가 . 가

가
가

IT

가 .

(1999). 가 . :

(2000). IT , 日, . 2000 9 4

- (1999). “ ”, 『 』, 2
2 , :
- _____ (2000). “ ”, 『 』, 3 3 ,
:
- (1998), , :
- (1998). “ ”.
「 」, 169-192.
- _____ (1998). “ ”. 「
」, , : , 40-49.
- _____ (2000). “ ”, 「 」, 4 , 50-55.
- 労働省(1996). 職業能力開発基本計画.
- 労働省(1999). 雇用・労働ワ - キング・グル - プ.
- 労働省(1999). 第9次雇用対策基本計画.
- 河合集雄監修(2000). 日本のフロンテアは日本の中にある - 自立と協治で築く新世紀,
東京: 講談社.
- 経済新議會(1999). 構造改革推進部會報告書 .
- 内閣官房(2000). 21世紀日本の構想.
- 佐藤義雄(1998). “産業界や地域との連携に立つ工業教育(1)”. 『産業教育』, 48 5
576 , 14-17.
- 佐藤義雄(1998). “産業界や地域との連携に立つ工業教育(2)”. 『産業教育』, 48 7
578 , 18-21.
- 文部省(1998). 我が國の文部施策.
- 寺田盛紀(1999). "高校教育改革における総合學科の役割." 『産業教育』, 第49卷 第2號,
通卷586號, 4-7.
- 佐藤義雄(1998). ものづくりを支える実践的な技術者育成の取組み. 『産業教育』, 48
1 572 , 14-16.
- Makino Atsushi(1997). Recent Development in Japan's Lifelong Learning Society.
(<http://www.lifelong-learning.org/makino.htm>)

.

1.

가.

가 가 HRD , HRD
 가 , HRD ,
 , , .

.

가 HRD .
 - .
 -
 - (, ,)

HRD , ,
 , 가 , ,

2.

가.

가 ,

3.

가.

가

, 가

(2000 2 300

가).

가 ,

-
- 99 75,000 가가 .
3 4 가 , 가

.

○

- ' ' ' '
- 가 가
- ' '

○

- .
· , ,
· ,
· , ·

○

- , 가
- : ,
· , .

.

○

, (Mittelstandspolitik), 가 .
 - :
 - : ,
 - : , ,

가
 - 2000
 - 2000
 10
 - , , 98
 , , ,
 , 3 , , 가
 (Virtual Town) .

.

. (, , ,)
 , .

가가
 Green Card IT 5
 ()

, ,

1.

○

가 , 가

가.

'가 가 1994 '
1998 '

- 1 :

· 50

· EU

· UNESCO, OECD

- 2 :

- 3 :

·

· (BAföG)

· ()

· (DFG)

·

· ,

- 4 :
 . 가 , , () , ,
 , .

- 5 :
 . 가

- 6 : , , ,
 .

.
 , , , , , , , / , ,
 , , , , .

- 1 :

- 2 :

. ,
 . ,
 .

- 3 :

. : , , , , ,
 , / ,

- 4 : (,)

- 5 : , ,

- 6 : , , , ,

- 7 :

가

- 1 :

- 2 :

- 3 :

- 4 :

- 5 :

- 6 :

가가 가

- 7 :

(BIBB)

(Hauptausschuß)

2.

가.

(Grundgesetze)

- : ' (Berufsbildungsgesetze)'

(BIBB) :

가

- : ' (Schulgesetze)'

(KMK):

16

(BLK):

가

8 ,

16 (

1)

· (Wissenschaftsrat):

(: BIBB

),

,

,

.

·

,

가

,

-

가

가

.

-

()

.

,

-

가

가

,

,

가

.

·

·

·

-

·

·

· BIBB

:

,

,

,

.

.

·

:

,

가

.

·

:

,

.

·

:

.

가 ,

:
(KMK):
KMK가 ()
,

-
가가

-
가 . . .
,

-
가 ()
).

-
가

-

· ·

가

가

-

가

(·)

1.

가

(Rütgers)

가

가

가

21

-

-

-

-
-
가.

10 18

가 .

가 .

2 .

(2003 8 1 3

2)

가 .

2001
160,000

, ,
 , ,
 .
 , ,
 .
 (BaföG)
 Habilitation (postdoctoral lecturing
 qualification)
 .
 Crdit-Point-System .
 ,
 .
 , 가 (:
 ,).
 ,
 .
 ,
 .
 , 가 , , ,
 , , ,
 , .

가

가

2.

70

30

가

가

가

가

“ ”가

가

가 가

가

가
가

가가

가가

가

가.

가

(KMK)

3

2

1

가

가

·

- ,

- , , ,

-

- ,

-

- 75% , 70%가 가

-

-

- 가

-

- :

- “ ”

- ,

- , 가

-

- , , ,

-

-

-

- ,

- “ ” 가

-

-

-

- 가

3 25 34 가 41 가 42 39 36

20 46 80 가 가 가 가

가 가 가 가 (34, 35, 42)

가

가

가

가 가

가

()

가

가

가

가

()

가

가

3.

가.

가가

가

8 14

1969

가

1969

1990 2

1990 6 22

OECD 가
(6.5%))

1%

가

가

가

. 1969

. 1974

75

76

가

IV.

가

(BIBB)

가

(BA)

가 (, ,)
 ,
 -
 , ,
 - 가
 가 가 ,
 ' ' ' ' ,
 가
 가 .
 , ,
 가 ,
 , 가 가 .

(1998). . .

(2000). , 『

』, 2000 6 3 3

(1999), (),

Ausbildungsordnungen(1992), BIBB.

Edelgard Bulmahn(2000), Speech by the Federal Minister of Education and Research in waschington on February 19, 2000.

Fragen und Antworten zum Dualen System der deutschen Berufsausbildung(1996), BMBF.

Impulse für die Berufsbildung(2000), BIBB. Agenda 2000plus.

<http://www.blk-bonn.de>

<http://www.bundespraesident.de>

<http://www.bma.de>

<http://www.bma.bund.de>

<http://www.bmwi.de>

<http://www.bmbf.de>

<http://www.mswf.nrw.de>

1.

- : , , ,
- : , ,
- : , ,
- : .

21

가 , 가 , 가

가 .

2.

가.

가

.

가

- 21 -

-

-

-

-

-

-

-

-

-

-

-

-

-

-

-

3.

가.

가

- , ,

-

(CDI: Centre de documentation et d'information)

-
- .
-
- (IUFM)
-
- (IUP, Institut universitaire professionnalisé)
- (CNRT)
- (IUT)
- , , , ,

-
-
-
-
-

-
-

- OPCA()

.

1.

가

가 (Ministère de l'éducation nationale, de la recherche et de la technologie) 가

[Empty box]

[Empty box]

가
(Ministère de l'éducation nationale, de la recherche et de la technologie)

(Ministère de l'emploi et de la solidarité)

[Empty box]

[Empty box]

[Empty box]

[Empty box]

[Empty box]

[Empty box]

[Empty box]

가

가

[4-1]

- '97 6 가
가 . . (Ministère de l'Education, de la Recherche et de la Technologie)

- 가
.

- (, , ,)
(, ,)

- (CNRS: Centre National de la Recherche Scientifique)

가 가

- .
-

가 .

-

가

, 가 .

. 가 가

, ,

, 가 (Ministère de l'emploi

et de la solidarité) .

-

,

,

.

가

.

-

,

.

2.

,

가

가

(, , ,)

-

, , ,

가

,

-

.

-

가

22

2 400
10 44 (Beaux arts)

, ,
.
()
- , - 가
.

, ,
.
()
- (Ecole
Polytechnique),

(:ENA)
- ,
.
, 가
.

3.

가.

.

.

- , , 가

- :

.

35 . 10
 , 10 , 5 6 ()
 , CEREQ, AFPA가) 11 (6
 , 2 , ,
 ,).

. . .

가

가 'U3M '

21 -

-

.

,
- 가

.
가 가 (,)
, ,) (, ,)
가 가
, 가 가

1.

가.

- 1994 5 , (Bayrou) ' (Nouveau
Contrat Pour l'Ecole)

- 3
(. , ,)
- 가 가
4

- 1
2, 3 4

가

(CDI: Centre de documentation et d'information)가

가

CDI

(20 10

)

(grandes écoles)-

가

가

· 3 (1966, 1970, 1975) 1966 860,000 ,

1970 870,000 , 1975 760,000 .

· , 1966 30.3%, 1970 38%, 1975

49.5% 가 , 1966

15.7%, 1970 20%, 1975 25% 가

, 1966 6.6%, 1970

7%, 1975 8.5% 가

(, 1966 8%,

1970 11.4%, 1975 16% 가 .

:

(baccalauréat)

(université)

- (grandes écoles),
(IUT, STS) (, , ,)

- , ,
6% 가 , ,
가
, IV)
가 2

. 60 70%
가 ,
가
(ENA : Ecole Nationale d'Administration) 20
(:
Sciences Politiques) 가
20 1 20
가

- 1971 (J. DELORS)

- 가 1
50% DEUG(
2), Licence(DEUG+1), Maîtrise(Licence+1), DEA(Maîtrise

+1), Doctorat(DEA+3 5)

50%

- 가

가

20 가 10 가 가

가 가 가

가

가

가

10 1989 7

(License,

+3) 2

2

2.

가.

-
-
-
- , 가, , ,
- 456 .
-
- 73,000 200 (1997-1998).
- 가 가
- 가 가 (Ministère de la Défense) (Ecole polytechnique) .
-
- 300
- 2
- (ENS, Ecoles Normals Supérieures)
- , 가
- 3-4 (maîtrise), (magistère), (DEA) ,
- 가 (agrégation) .
- , ()
-
- (Ecole nationale des chartes):
- (Ecole nationale supérieure des Sciences de l'information et des bibliothèques):
- (Institut d'études politiques de Paris): 가
- (ENA, Ecole nationale d'administration):

- (DUT, Diplôme universitaire de technologie)
 - (IUT, Instituts universitaires de technologie)
 - 88 .
 - 2
 - 10 3 , 2 · 3 ()
 - , , , , , , ,
 - 24 .
- (BTS, Brevet de techniciens supérieur)
 - (BT, Brevet de techniciens)
 - 2 ,
 - (STS, Sections de techniciens supérieurs)
 - (, , , ,)
- (DESS, Diplôme d'Etudes Supérieures Spécialisées)
 - 3 (Le troisième cycle) ,
 - 3 가 , 1
-
- (DEUST, Diplôme d'études universitaires scientifiques et techniques)
 - (2) , 6 1
 - DEUG .
- (MSG, Maîtrise de sciences de gestion)
 - 1971 2 , DEUG
 - ,
- (MIAGE, Maîtrise de Méthodes Informatiques Appliquées à la Gestion)
 - 1970 2 1,600 가 1
 - 2 . ,
- (MST, Maîtrise de sciences et techniques)

- DEUG , DUT BTS 가
- (Magistère)
- 1985
- (BAC+5) DEUG ,
- , 3 . ,
- (IUP, Institut Universitaire Professionalisé)
- 3 , 1/3
- 2 가 .
- IUP 1 DEUG CPGE 1
- BAC+1(1) .
- IUP 1 「 (DEUG)」, 2
- (LICENCE), 3 「 (MAITRISE)」 「 -
- (Ingénieur-maître)」
- (Diplôme d'Ingénieur)
- 92 DEUG 3 .
- .
- (IUFM)
- 「1989 」 ,
- (BAC+3)가 가 . 1
- 2
- (DRT, Diplôme de recherche technologique)
- (IUP)
- 가 - -
- 12-18 , 3
- (IUP) .

- , 가

- 1983 가 , ,

- , 9

- 1 16 25

- (Contrat d'orientation)

(1991 12 31 no 91-1405).

(L. 981-7, al. 1 L. 122-2).

- 가 .

- 가

- 2000 12 31

- 26 가 .

- 가 .

- . (R.115-1)

- ,

- ,

4 1

가

가

CPNFP, COPACIF, AGEFAL

· CPNFP

1991 7 3

CNPE, CGPME,

UPA가

CGT-FO, CFE-CGC, CFDT, CFTC

가

· CPNFP 1991 7 3

2

(8)

16

1

가

1982

COPACIF

가

가

(CIF)

가

AGEFAL 1986 12 22

1901

· CPNFP

· OPCA

가

, , OPCA

CPE가

1969

2 10

(ANI)

. 1991 7 3

CPNE,
1984 7 6

COPIRE,

CPE

OPCA,

· 1971

OPCA

가

· 1994 7 5

1991 7 31

(ANI)

가

OPCA

· 1995

1996 1 1 97 가

1998

99 .

가

가

(comité d'entreprise)

2

()

1984 4 1

가

가

(AUD : allocation

unique dégressive), (ACA : allocation chomeurs agés),
(AFR : allocation formation reclassement) 가 .

8

(1998 1 28 UNEDIC no 98/ 04)

- 가
가

(ASS :
allocation de solidarité) (AI : allocation d'insertion) 가
가 .

- 가
가 UNEDIC
ASSEDIC .

- (Diplôme), (titres homologués),
(certification de branche) 가
가

-
(commission technique d'homologation)
· 1970 (titres homologués)

- (certification de branche)

· 35 : 10 , 10

, 5 6 (,
CEREQ, AFPA가) 11 (6 , 2
, ,
).

. 3 17

- 1980

1990

가

-

-

(bilan de compétences)

가

-

, , 3가

-

-

(2 · 1).

가

가

-

가

-

가

가 .

가 가 .

3.

가. .

「1989 7 』(Loi d'Orientation sur l'Education)

- 1990 2000 , 10

가 .

1 , .

「 』(RPL, Rénovation Pédagogique des Lycées)

- 1991 (L.Jospin) , (F. Bayrou)

- 「 (RPL)」 1990 가 (CNP)가

- ,

- “ 가 ,

가 ”

「 2000 』(Université 2000) (1991)

- 「 2000 』 (1991)

, 2 , 1

1991-1995, 2 1995-2000

- 「 2000 』

.

.

.

가

- 「 2000 」

· 1991 10 27

(IUP, Institut universitaire professionnalisé)

· 1

3

· , , , ,

·

· 2가 ,

가 .

(Bayrou) 「 」(Nouveau Contrat pour l'Ecole, 1994 5)

- 1994 5 , 「 」 .

, 가

, , 가 ,

, ,

- 「 」 ,

가 ,

3 , , , .

- 1993 11 126-127 1994

12 1995 3

. ,

, ,

가 .

-

‘ (1995 3) ,

‘ ‘

(1994 12), ' (Youth
for Europe) (1995 3) . '

(Projet Fauroux, 1996 6)

- 1996 6 13 , .

(Bayrou)

- 1997 2 4 , 1995 10 18 3
. 1 1995 10 1996
4 가 , 100

(, ,)

. 2 1996 4 6 ,

197가

"

'(Les Etats Gènèraux de l'universitè) 50 .

- 1997 2 1997 9

(C. Allègre)

- 1997 6

- (aide-èducateur) 1998 1 1 7 5 , 3

15 ,

- . 1997 4,000

2,000 1,500

- , 9 412 , 500

“ ”

- (éducation civique)

(CPGE)

) 가

: 「 가 가?」

- (C. Allègre)

가 가

가 . 1998 1 8 -23 ,

300 40 4,500 “

가 가?(Quels Savoirs Enseigner dans les Lycées?)”

- , , 가

‘U3M ’ (가 , 1999. 12)

- 21 -

-

- ‘U2000 ’ 가

- 2000 2006 450 (270 ,
180)

'U3M '

- (IUT)

. 2 (DUT)

가

(BTS),

- "U3M " (2000 2006)

3

"U3M "

(CNRT)

1998 1 8 , 21

-

(Edgar Morin)

“2000

,

”

,

,

21

- 6 20

3

-

(6. 19) 63%

-

,

,

,

,

,

(, 1999. 3)

-

1.

,

가 , 가

, 가

가

2.

, ,

, .

가

가

가

7

.

, ,

가 .

가

.

.

3.

가

.

,

,

4.

,

가

5.

1980

1990

가

가

가

6.

가

가

20

10

가

가

(1994). 가 . : .

Audigier, F. et Lagelée. G(1996). *Education civique et initiation juridique dans les collèges*. Paris. INRP.

Centre inffo (1999). *Les fiches pratiques de la formation Continue*. Centre inffo.

CIEPP et CGP (1997). *La loi quinquennale relative au travail, à l'emploi et à la formation professionnelle*. La documentation Française.

Couvreur-Houdelin. H (1987). (dir.) *Education civique 5^e*. Paris. Bordas.

_____. *Education civique 4^e*. Paris. Bordas.

Delouche(). (1992). *Histoire de l'Europe* Hachette. Paris.

- Demonque. C (1994). *Qu'est-ce qu'un programme d'enseignement ?*. Paris. Hachette.
- Durand-Prinborgne. C (1991). *Le système éducatif*. Cahiers français. No 249 jan.-fév.
- Fumat. Y. (dir.) (1998). *Education civique 4^e*. Paris. Nathan.
- Hanniet. J.-P. (et all.) (1997). *Education civique*. Paris. Bordas.
- INSEE (1999). *Données Sociales. Paris*
- Mateur Françoise (1998). *Histoire Générale de l'enseignement et de l'éducation en France*. Paris.. Nouvelle Librairie de France.
- MAUROIS André (1998). ().
- Ministère de l'Education Nationale(1996). *Bulletin Officiel de l'Education Nationale*. No 7 mars 1996. Paris. CNDP.
- _____. (1996). *Bulletin Officiel de l'Education Nationale*. Programmes de 6^e. Paris. CNDP.
- _____. (1995). *Programmes de l'école primaire*. Paris. CNDP.
- _____. (1985). *Collèges : programmes et instructions*. Paris. CNDP. Ministère de l'emploi et de la solidarité (1999). *La formation professionnelle. Diagnostics, défis et enjeux*
- Ministère du travail et des affaires sociales(1996). *L'Altermance: Enjeux et débats*. Paris. La documentation française.
- _____. (1996). *Donner un nouvel élan à la formation professionnelle*. Paris. La documentation française.
- Zanghellini. Valery (dir.) (1986). *Education civique 6^e*. Paris. Editions Belin.
- _____. (1986). *Education civique 5^e*. Paris. Editions Belin.
- _____. (1986). *Education civique 4^e*. Paris. Editions Belin.
- _____. (1986). *Education civique 3^e*. Paris. Editions Belin.

1.

: 가

가

: , , , ,

2.

(Council of Ministers of Education Canada: CMEC)

-

- CMEC

-

-

-

,

(Human Resource Development Canada, HRDC)

“people department”

-

-

, , , ,

-

,

,

-

.

.

-
- (preventive measures)
-
-
-
- 가
-

(Industry Canada):

-
- ,
- , 가
- , 가
-
-
-
-
-

3.

- :
- (HRDC) (Industry Canada)가
-
- (CMEC) , 가,
- (College of Teachers),

(Council of Ministers of Education Canada: CMEC)

- CMEC

- : , , 13-16

가 .

- (best practices) .

- .

- , (open learning),

- .

- .

- .

- .

- .

- CMEC

(‘95 -)

· (Information Technology in Education)

· .

· K-12 1995 2000 6 30

· , 가 가 21

· .

· .

가 가

(literacy)

· .

· (州) .

· .

· (Community

Access Program)’

· .

SchoolNet

· .

	<u>School Net</u> <u>TeleLearning Network</u> (Csile, Virtual-U, Teleform, Cadretel)	
(州)	- Grassroots - SchoolNet - ENO/REA	- PLNet - CLN

[5-1]

- SchoolNet PLNet “ (ICT; Information and Communications Technology)

- ICT
- ICT
- ICT ()
- ICT , ,
- ICT 가
-

(HRDC)

- , , , ,

, ,

.

- :

가

-
-
-
-

.
 .
 - : 가 가 가
 , ,
 .
 - : , , (migrant)
 , .
 - : ,

(Industry Canada)

- , ,
 .
 - 3
 5가 .

.
 .
 .
 .
 .

1.

(CMEC) , HRDC
 , (Industry Canada)

2.

, , ,
 .
 (CMEC) , 가
 best practice .
 (Statistics Canada) .
 (HRDC) , (school-work
 transitions) .
 (Industry Canada) SchoolNet
 .
 (Social Sciences & Humanities Research Council: SSHRC)
 .

3.

- (Council of Ministers of Education Canada)
 가 .
 - 가 Council
 of Ministers of Education Canada(CMEC)가
 .
 - 가 ,
 (best practices) , ,
 . , , ,
 ,

- Sectoral and Occupational Studies Division, HRDC가 .
- 가
- , , , .
- 가 가 가
- , , , 가
- .
- Human Resource Partnerships
- Directorate가 가
- 가 .
- , (ownership) .
- , .
- , 가 .
- , .
- , .
- .
- Ontario The Federal Economic Development Initiative in Northern Ontario(FedNor)가
- (SchoolNet) 1993

- SchoolNet

SchoolNet 가

Networks .

- SchoolNet

·

·

·

·

·

·

-

-

of Excellence

TeleLearning Network of Centres

가

가

· telelearning

·

- 가 (Prior Learning Assessment and Recognition: PLAR)

- 가

- "Red Tape" :
()

- Yukon Dept. of Education First Nations, 가

•

가

가

가

- 가

가,
1
가

1.

Ontario

- 1990
가,
가 (Education Quality & Accountability Office)
1997 가 3, 6,
9, 11 가

- 1-8, 9-10 , 1-8
가
A4 40-60
(<http://www.edu.gov.on.ca>)
가
3-5
, 11-12
가

14 , 3

가 가

가

(professional development days)

, internet

4 가 (OTF)

가

< 5-1>

/ (goals/ outcomes)	(measures)	/ (targets/ standards)	98-99 (commitment)
가 :	가 가 3	3 가 4 3	1998 가 가 2%

< 5-1> . ()

/ (goals/ outcomes)	(measures)	/ (targets/ standards)	98-99 (commitment)
:			1998-99 1-8 1999 9-12
		가	가
:		3 61% 65%	1998

< 5-2>

/ (goals/ outcomes)	(measures)	/ (targets/ standards)	98-99 (commitment)
:	, 6 - - -		1998-99 가 - - -
	,		25-29 1 ()
가 :	18-24	(34%)	30) (1

(: (1999), APEC ,)

Quebec

85%

20

60%가

30%가

-

- 가

-

-

-

-

New Brunswick

-

- 18 (district)

-

- 1999 18

Northwest Territories

- 가

가

- Dene Inuit

. 2004

Alberta

- Alberta

School Career Transitions Initiative

-

\$850

- Alberta Advanced Education & Career Development:

· 5-10

·
가

Manitoba Dept. of Education and Training

- 가

-
(articulation)

2.

- Youth Internship Canada:

- Youth Service Canada:

- Students Summer Job Action:

- Yukon Dept. of Education Youthwork, Entrepreneurship, & Jobs

- Manitoba Dept. of Education and Training 가

:

가 가

- Manitoba Dept. of Education and Training

:

:

가

(Standards Development Committee)

- 가
- 가 가
- 가
- HRDC , Sectoral Partnership Initiative

3.

Work-Infonet

- (Canada Student Loans)
- Canada Education Savings Grant

- (Canada Pension Plan)
- (Old Age Security)
- / (Income Supplement/ Spouse's Allowance)

- 가 (Self-employment Assistance)
- (Targeted Earnings Supplement)
- Skills, Loans and Grants
- Federal-Provincial/ Territorial Arrangement

(Occupational Safety Compensation)

Work-Infonet:

- Work-Net , 가 (National Occupational Classification),
- : , , , / ,
- : , , / , /
- NOC(National Occupational Classification): ,
- : , , / /
- : , , ,
- : , , , 가

. 1994

가

1

1

2

(4+1 or 4+2)

가

Quebec

가

가

가

가

13-16 (CMEC) 가
99%

Youth Internship Canada

가

Youth Service

Canada

가 가 가 가 가

(1999). APEC 가
(1999). 가 :

(1999). OECD 가 : ,

(1996).

[http:// info.ic.gc](http://info.ic.gc) industry Canada

[http:// www.hrdc](http://www.hrdc) Human Resource Development Canada

[http:// www.cmec.ca](http://www.cmec.ca) Council of Ministers of Education, Canada.

.

1.

가.

가 .

' 가 , 가 '

. 가 가 가 .

- , ,
- ,
- 가

, 가

가 .

- ,
- ,
-

가 .

.

,
- 가

,

-

가

가

가

가

가

가

가

(social exclusion) 가 (social inequality) 가

가 가

가

가

가 (virtual economy) 가

가

- ,

, 가 ,

2.

- 가 , 가
,
(telecommunication market)

- , , TV

- 가

- ()

- , ,

- (knowledge-based society) 가
가

· , (ICT) 가, ,
가 .

- , , 가
- .

3.

가.

가

- .
- .
- 2004 E-mail .
-
-
- 가
- .
-
- , 가
- . 가 가
-
- 가

-

- 가

- 가

- , ,

- 가 NGO

- , , TV,

- 250 (Sittra) (The Technology Development Center)

가

-

3

-

- , 5

- 가 . ,

- 가 . .

가

- 가 .

- (The National Education Board), , (The Finnish national Broadcasting Company, YLE), ,

, NGOs 가 가

- 가 . 6

- . .

- .

- ,

- , 가 3.3

- .

- 가 . ,

- . 가 .

- , .

- ,

1.

(The Department of Education and Science Policy in the Ministry of Education, DESP)

2.

가.

가 (the Council of State)

가 , , ,
(National Board of Education)

-

-

-

-

-

-

-

-

.

-

-

-

-

가

가 가

가 가

가 가 (Finnish Higher Education Evaluation Council), (The National Board of Education), (The Finnish National Fund for Research and Development, Sitra), (The Council for the Promotion of the Information Society through Education, Research and Culture)가

가

가

/

가

가

,

가

가 가

·
-
· · · ·

-
,
- ,
- ,
- 가

가 가 ,

- · · ·
- ,
-
,
·

- 1998-2002
-

- 가
(Polytechnic, 3 4

. ,
.

가 .

.
.
- .

.
.
.
- . 가

. , , 가

.
.
.
.
.
.
- 가

. 가 .
.
.
.
.
.
.
.
.
.
.
2 5 , ,
.

2.

5 .

- 2000

(comprehensive school)

E-mail

,

,

.

-

,

,

가

-

,

,

가

-

,

,

-

.

-

· 「

.

.

가

,

2000-2004」

·

·

·

· 가

가

·

·

,

,

,

-

·

3

1

가

·

가

2004

2 5

가

-

·

8

- 6
-
-
-

EU

1998 3 ' 1998-2002' ,

- ()

- 2000 1998 1,000
- 1998-2002 5,150

- 1999 60 ,

- 2001 1998 1,400 ,
- 1998-2002 가 2,400 ,
- 1998-2002 1,000 ,

- 1998-2002 400 ,

3.

가.

9

- 7

- 3 1994 가

가 2-3 1-2

가 1994 ,

- 1980 7 30

가 : , , , , 1
: 14
()
, 가 : , , 가 ,
:
:
: 가 ,

- 가 가 , 가

가 2-3 .

가 .
(licentiate) . 20

1991

. 1996

, 2000

OJT

-

OJT

- 1998 1

OJT

-

가

(work-based learning)

- 6

-

- ()

(Agreement on Training Provided in Connection with Practical Work at the Workplace)

4.

가.

-

(1960-1970)

-

2

(1970

)

-

(1980)

-

(1990)

-

(1990)

-

가

- (University Act) 1998
 - 1999 1999

- 가 14%

- 1999 GDP 3.8%
 266 FIM 5 7,700 (99 8

1FIM=216.92)

- 1999

- . 27.7%
- . 22.8%
- . 14.3%
- . 10.8%
- . 6.7%
- . 6.0%
- . 4.1%
- . 3.8%
- . 1.9%
- . 1.2%
- . 0.5%
- . 0.1%
- . 100%

- 16 FIM(3,470
) EU Structural Fund 2 FIM(433
)

- 20 FIM(4,338)
 . 가 (National Lottery)
 (51%), (23%), (20%), (6%)

· , , , ,
 ,
 · (the Academy of Finland)
 , 가
 .
 · , ,
 .

1998-2002
 7 8 FIM(1,691 , 1999
 8 1FIM=216.02)
 - , 2006 4 4 FIM(
 954)

(Training Committee)

- 가 가

1.

- 가
 - 1999 55 2

- , , ,

- ,

가 . .

- contents

가

- 가

- 가 가 가

가

, 가가

가

가

2.

가

. .

-

-

-

-

-

-

-

-

-

가

(1999). Education and Research 1999-2004.

(<http://www.minedu.fi/julkaisut/KESU2004/eng/engKESU.html>)

(1999). Finland's National Action Plan for Employment 1999.

(<http://www.mol.fi/nape>)

(2000). Finland's National Action Plan for Employment, April 2000.

(<http://www.mol.fi/english/reports/nap-eng200001.html>)

(2000). From Information Society to Knowledge-based Society.

(<http://www.mol.fi/english/index.html>)

OECD(1998). Thematic Review of The Transition From Initial Education To Life,
Finland: Background Report.(<http://www.oecd.org/copyr.htm>)

.

1.

가.

(Human Resource Development, HRD)

(training and development)

(capacity building)

.

2.

「 . . . 」

-

-

(MCEETYA, 1999).

(ANTA)

- 가

가

-

, ,

-

-

-

가

-

-

-

-

()

-

3.

가. 「 . . . 」

(, ,)

가

가

「 . . . 」 ,

가

()

(1998-2003)

가 (Australian National Training Authority, ANTA)

“

가

(架橋):

1998-2003

가 ”

가 가 .

가 가

, , .
, ,
, 가 ,
, .

가 5가

(mobility)

1.

○ (Department of Education, Training and Youth Affairs, DETYA)가
(Department of Employment, Workplace Relations and Small Business, DEWRSB) (Department of Industry, Science and Resource)

가. 「 . . . 」

○ : 1987
(Department of Employment, Education and Training, DEET) 1996
(DEETYA) 가 1998 10 . . .
,
(DEWRSB) . DETYA .

-

-

가

-

-

-

-

-

-

, 가

-

-

. 「 . . . 」

:

, .

· , ·
:
, ·
(,) ·
,
·
- : ·
- 가 :
·
- :
- : IT
- ,
·
- : , ,
, , , ,

2.

가. 「 · · 」

· · :
·
-
-
-

3.

가.

6 2 가

, 가 가 , .

가 가
가 .

**(Ministerial Council on Education,
Employment, Training and Youth Affairs, MCEETYA)**

- 1994 MCEETYA , , ,
(commonwealth), (state), (territory),
(Norfolk Island)

- 가 , , ,
, , / ,
, .

(ANTA MINCO)

- MCEETYA , 가
가 ,
, 가

- 1 가 , 1
가 가
(taskforce)

가 (Australian National Training Authority, ANTA)

- ANTA 1994 1 . ANTA
(Board) 가 , ANTA MINCO()
7 ,

(Industry training advisory bodies -ITABs)

가 ITABs

1993 44 가 ITABs 가 , 1994
1996 , 44 가 ITABs가 23 5
6 가 가 ITABs 130

ITABs

ITABs

가

()

1994 가
(Australian Student Traineeship Foundation, ASTF) . ASTF
가
가 . 11 12

1995 1996 7,500
 . ASTF - ,
 가 .

1.

가.

2 , 3-6 . 6 , 4 ,
 11, 12
 10
 가 TAFE(Technical And Further
 Education) 가 .

(School Sector) (Vocational Education and Training Sector),
 (Higher Education Sector) .
 (School Sector) 가 ,
 () () . 3 2가
 가 , 4 1가

(Higher Education Sector) ,

21

가

- 1999 4

'21

가

'21

가

1989

- :

. 가

- 가

.

.

, 8

, , , 2 , , ,

, , 가

-

DETYA

(literacy),

, ,

,

,

.

.

-

.

-

-

,

.

(HECS)

(OLDPS)

-

(Higher Education Contribution Scheme, HECS)

25%

(Open Learning Deferred Payment Scheme)
(Open Learning Australia)

- 1999 12

· ARC
·
funding)

가

(performance-based

2.

가.

(Technical and Further Education,

TAFE)

(ACE)

TAFE

230 가 . TAFE

가

TAFE

가

(OTEN)

TAFE

○

- (Competency-Based Training, CBT) 가

- CBT

가 가

- CBT

가

가

가

-

CBT

가

가

(National Training Board, NTB)가

-

가

(

),

,

,

,

가,

,

(New Apprenticeships)

-

,

,

(

)

가 , 가 .
 - 가 .
 가
 - (AQF) 12
 (TAFE), ()
) . <
 1> .

< 7-1> (AQF)

Schools Sector	Vocational Education & Training	Higher Education Sector
		(Doctoral Awards)
		(Masters Degree)
		(Graduate Diploma)
		(Graduate Certificate)
		(Bachelor Degree)
	(Advanced Diploma)	(Advanced Diploma)
	(Diploma)	(Diploma)
(Senior Secondary Certificate of Education)	4 (Certificate)	
	3 (Certificate)	
	2 (Certificate)	
	1 (Certificate)	

○

- 1 (Certificate) : 4 (10)
) 가 .
 - 2 -3 (Certificate -) : 4 (10)
 가 , 1 가

- 4 (Certificate):

, 가
(12) , 3 가

- (Diploma):

. (12)
4 가 가 . , ,

- (Advanced Diploma):

. (12) , Diploma

. 1-4

, 가 (State Recognition
Authority, SRA) (Register of Training
Organization, RTO) 가 , 가 , 가

가

가 (AQF)

가

가

가

(training package)

가

, TAFE

가

가

(Recognition of Prior Learning, RPL)

3.

가.

가

TAFE

TAFE,

44%,

38%,

18% (ABS, 2000). , 56% 가
가 1998
(GDP) 4.4% .

가 , 6 2 ,
가 가
.

(. .) , .

가 (Australian Qualifications Framework, AQF)
(Integration) . (AQF)

가

가

가

가

가

, ANTA , TAFE, 가
(NBEET) 가 (NCVER)

(1999). “ ,”

(1998). 21

가

Australian Bureau of Statistics(ABS, 2000), *2000 Year Book Australia*, ABS.

Australian National Training Authority(1999). *the ABC of Vocational Education and Training*.

Australian National Training Authority, *Australia's National Strategy for Vocational Education and Training 1998-2003 A Bridge to the Future*, ANTA.

Australian Qualifications Framework Advisory Board(1998). *Implementation Handbook*.

Australian Research Council(ARC, 2000). *ARC Strategic Plan 2000 to 2002*.

ARC.

Department of Education, Training and Youth Affairs(DETYA, 1999). *Corporate Plan*.

NCVER(2000). *Australian Vocational Education and Training: An Overview*, NCVER.

<http://www.anta.gov.au/About/default.htm>.

<http://www.deet.gov.au/annualreport/files/>

<http://www.curriculum.edu.au/mceetya/index.htm>

<http://www.curriculum.edu.au/mceetya/nationalgoals/>

1.

가.

가 (Cool Britain)'

'Cool Britain' 가

가 2000 2000

(learning society)'

2000 가

가

" , , , .

"()

가

20-40% , .

· (learning society)'

가

가

2.

가.

가

- 가 (The Learning Age)' 1998 가

가

가

가

.

- 가 .

. 16

, , .

,

가

.

.

.

,

,

가

. 가 가 . , ,

.

- 가

. 가 , , ,

. , ,

. ,

.

- 가 ,

3.

가.

(heart)

.

- 가 21

.

1991 가 (National Targets for Education and Training: NTETs)가 , 가

가 (New National Learning Target)

가 2002 가 (National Learning Targets)

-
· 21 60% 3

-
· 50%가 3
· 28%가 4
· 1/ 3

-
· 45% (Investor in People)
· 10,000 (Investor in People)

- 가 .

- 가

- , ,

-

-

-

-

(FEFC)

- FEFC

가

(Training and Enterprise Councils: TECs)

- 가

(Local Authorities: LAs)

- , ,

(Government Regional Offices: GROs)

- 3 , , ,

(Regional Development Agencies: RDAs)

(Training Standard Council: TSC)

- 가 가 , 가

(National Training Organization: NTO)

- 가

(Employment Service: ES)

- (executive agency) 1,000

(Job Centre)

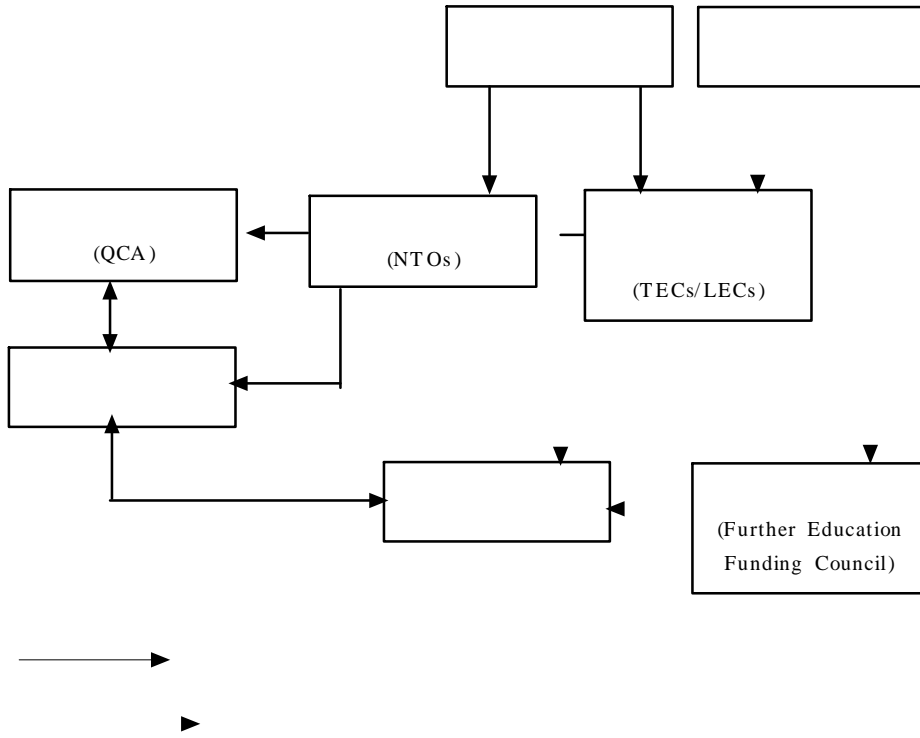

[8-1]

3.

가.

- , 가 .
- .
- 가 (National Curriculum) 가
- 가
- .
- .

- , 가

.

가

가 (,)

-

가

(Output-related funding: ORF)

- " , , " .

.

-

-

(NTO) 가 .

16 .

(Modern Apprenticeship) 가 (National Traineeship)

(, , 3 가

, 30 40 -

가 40 , -)

(National Training Organization: NTO)

, 가 (NVQ) 2 3

가 , ,

가 , ,

, , 가 가

, .

가

- 9 1 , 가 1999

가

가

16 17

(further education)

. , ,

.

1.

1997 ,

, .

가

.

-
- 가
-
-
-
-

가.

4가 (Pre-compulsory education), (Further Education: FE), sixth form 가 institute, institute()가 5 16 19

11 16 , 90%가 Comprehensive School

(General Certificate of Secondary Education: GCSE) 가 Sixth Form Sixth Form College (GCE A-level .)

(Grant Maintained Schools)

- 가 (School Governing Body)가

- 1989 1999 1,200

1/5

가

가

1999 9

-

가

- 1998-1999

13

(

,

9000

+

1

1

63

)

,

1

+

1

21

(

1

63

)

,

1998-1999

,

가

,

,

가

1996/ 97

280

,

1/3

가 2002

50

2.

가.

- (Secondary Modern School), (Comprehensive School), (Technical School), (CTC: City Technology College) , GNVQs

Polytechnic

가

Education College)

16

19

(Further

-

, Sixth Form

Sixth Form

가

- (: Work Based Training for Young People: WBTP)
 16
 ,
 가 .
 - (OJT),
 , (open learning) , , ,
 ,
 - 25 -63 (Work Based Training
 for Adults: WBTA) 18-24 (New Deal) .

가 3가 .
 - GCSE GCE
 A level .
 - GNVQs(General National Vocational Qualifications).
 - NVQS(National Vocational
 Qualifications).
 -

가 . 1997 가
 가 (QCA: Qualification and
 Curriculum Authority) .

가
 , 가
 가 가 .

3.

가.

1979

- 1988

가 16 4 가 가

가

- 1991 (Parent's Charter)

가

- 1992 (OFSTED)

가

가

1998

가

- ' 1998 2

(the University for Industry), (Individual Learning Accounts)

(University for Industry), (Individual Learning Accounts), (Career Development Loans)가

(Investor in People)

		가	
-		(Skills for Small Business)	
·	50		1-2
-		(Small Firm Training Loans)	
·	1994	, 50	
-		(The Local Competitiveness Budget)	
·	1997-98	, ,	
-		(Investor in People: IiP)	
·	1991	,	
-		(Career Development Loan: CDL)	
·		80%	
		, , , ,	
	가	2	
-		(Vocational Training Loans)	
·		가	
-		(Individual Learning Account)	
		가	25
		150	34
		100,000	12

· ,

(2) , 50 ,

· 20-80%

(1 500) .

· ,

가 .

- (the University for Industry)

· ,

5 250 , 가

· (Learning Direct helpline)

· ,

1998-99

880 , 420

(Windfall Tax)

· , , , ,

() ,

· ,

·

CD-ROM 가

·

(, ,)

- 가 (NGFL: National Grid for Learning)

· 가

· , , , , 가

· 가

· ,

-

가

1.

1996 1

“ , , ” (,)

- 가 , , .

(Career Development Loan), (Vocational Training Loans), (Individual Learning Account)

(Skills for Small Business), (Small Firm Training Loans), (The Local Competitiveness Budget), (Investor in People)

() 가

가

- , 가

가

- 가

가

2. () (Welfare-to-Work)

가

- (, ,)

· ,

- ' , ' ,

.

3. (Output-Related Funding)

regulator

· ,

,

- 가

· NVQ ,

가

가

.

-

)

(

가 .

4. Social Partnership

가

가

(low

skills equilibrium) , 가

가 , 가

가 가

() 가

가

CEDEFOP(1994). *Vocational Education and Training in the United Kingdom*.

. 1996.

CEDEFOP(1997). *Apprenticeship in the UK*.

CEDEFOP(1998). *United Kingdom: Developments in Vocational Education and Training*.

CEDEFOP(1999). *The Financing of Vocational Education and Training in the United Kingdom*.

CEDEFOP/ EURYDICE(1995). *UK: Structure of the Education and Initial Training System in the European Union*.

DfEE(1998). *The Learning Age*.

DfEE(1999). *Departmental Report*.

DfEE(1999). *Education and Training Statistics For the United Kingdom*.

Donald Mackinnon, June Statham(1999). *Education in the UK*.

OECD(1999). *Thematic review of the transition from initial education to working life(United kingdom-country note)*.

1.

-
-
- 가 3
-
- 「
(workforce investment act)」
-
- ,
- ,
가 ,
-
- 「 」
- , (one-stop delivery system)
- , (individual training
account)

· , 6
· , 6
· ,
- 14 18

· ,
· , 가
· , , ,

가 ,
가

· , 가

() - 2020 60%가 가 22% .
(human resources positioning the united states for scientific and technological leadership and for workforce productivity in the twenty-first century).

- 1999 1 (committee on labor and human resources) , , (committee on health, education, labor and pensions) .

- , , , 가
-
- .
- 30
(health and human services agency)'가
(department of human services)'
-
가 .

2.

- ,
- : ()
.
.
.
.
-
.
6 가
.
.
.
.
-
.
.
-
.
3
· 8
· 18 가 가 .

- 가 .
- 2000

() (technology literacy) : , , (The National Information Infrastructure : Agenda for Action ; [http:// metalab.nuc.edu/ nii](http://metalab.nuc.edu/nii)).

-
-
-
-
- , , ,
- ,
- , , ,
-
- , ,

-
- , ,
- , ,

-
-
- 가
-
- 가

3.

- 가 .
- , ,
- 21 (21st century workforce commission) 가
- 가
- 21
- 9가
- , 21 (literacy) :
- , ,
- , : 21
- 가
- , :
- , IT : IT
- , IT : IT
- IT
- , :
- , IT : IT
- 가
- , : 21
- , :

- 1998 2002 (goal)

- 가 ,
-
-
- ,

-

-

(annual plan)

-

-

가

- 1997 2002

- 1: -
- 2: - 가
- 3: -

- 1 :

- ,
-
-
-

- 2 :

-
-
-

- 3 :

- ,

- 가
- 가
-
-

-
- 가
- 가

1.

「 (government performance and result act, GPRA)」

‘ (comprehensive performance accountability system)’

가

가

urban development)' .

(unemployment trust fund accounting system) 가 가 .

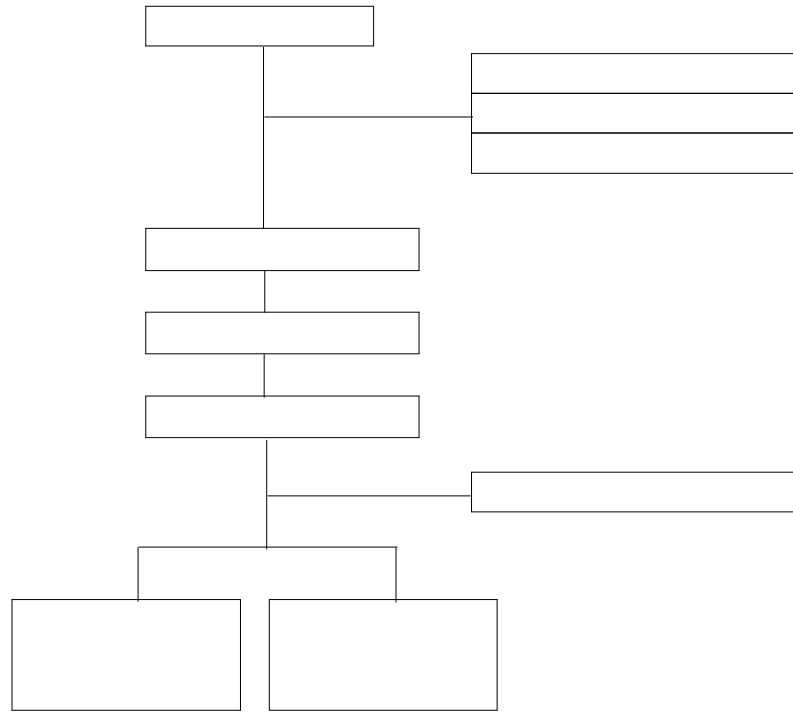

[9-2]

3.

가

가

가

8%가 , 50%가 , 42%가

(performance)

(funding)

가

(state) 가

가?

가

(technical assistance) (가?)

가

5%

- 가

- . , .

(employment and training administration, ETA) ,

(occupational safety and health administration, OSHA)

(national institute for occupational safety and health)

- ,

가 . (house appropriations subcommittee),

(house education and workforce committee)

- 가 school

to work . , 가

- 「 가

가

가 .

- , , , ,

- .

-

가 (The corporate imperative)' 1998

- .

- .

- .

- ' (strategic partnerships)' .

가 , .
 . 1980 , ,
 , 1991
 . 1994
 . 1997 23 927 15
 . 3,000

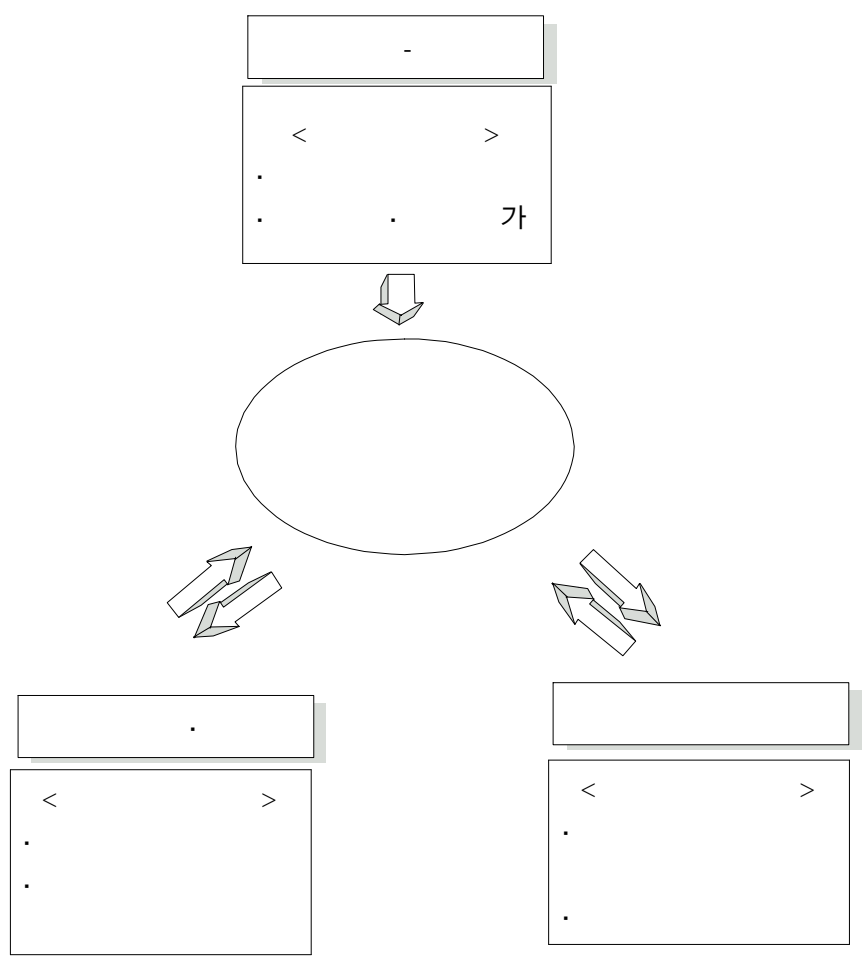

[9-4]

(new american schools): , .

, , ,

-

가

-

-

-

- Hope (hope scholarship credit)
- (the lifetime learning tax credit)

-

- PONSИ(the national program on noncollegiate sponsored instruction) ACE
- PONSИ

·

4,500 PONSИ 250 가

·

가

2.

-

가 . 가

-

가

- Tech Prep

·

· 4

2

·

· TPAD(tech prep associate degree) :

2 2

· ITP(integrated tech prep) :

· WBTP(work-basede tech prep) :

- (school-to-work transition opportunities act)

.

.

.

, , , (school-based learning)

(work-based learning) .

- 'School to Work' 'Work to Work'

.

- National Technological University(NTU)

· 6 " (Bringing World-Class Distance Education to the Technical Community)" 가

NTU 50

(

)

- , , 가 .

- 가

- , 가

- (America Labor Market Information System, ALMIS)

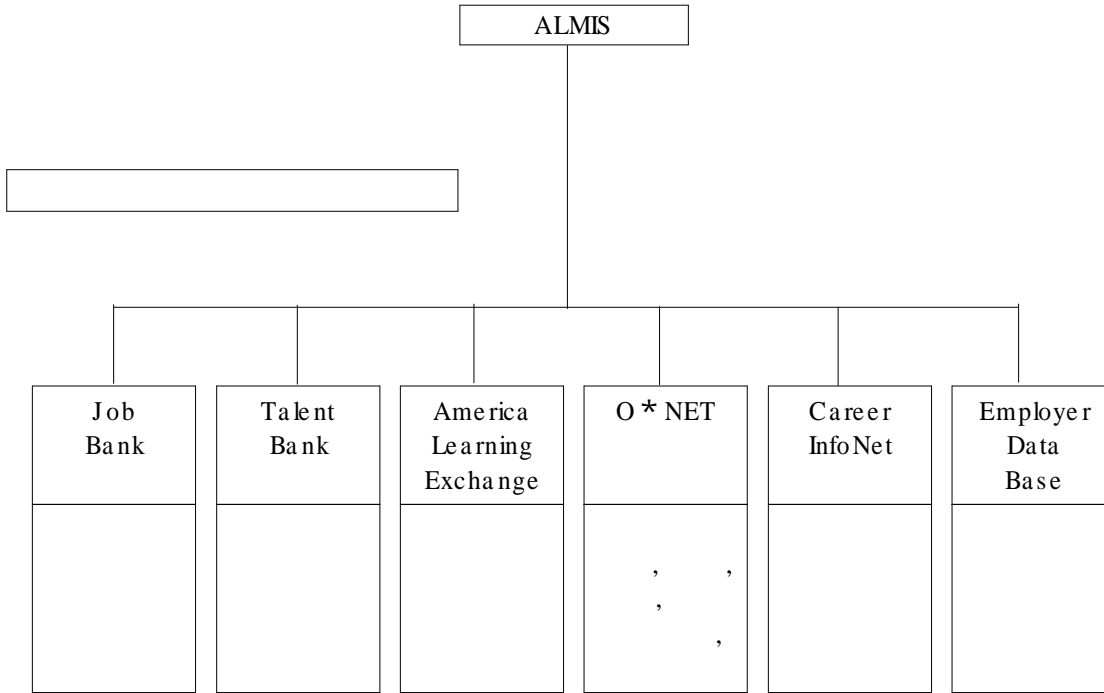

[9-5]

- (America's job bank): 150 가
- (America's talent bank): 가
- (America Learning eXchang/ ALX): , , 4
- (occupational information network, O*NET):
- (America's career infoNet, ACINET): , , ,
- (employer data base): , , ,

- , , , .
- (lifelong learning summit)
- 21
- 高 , 高 가
- 10
- , 「
- 」 6 가
- , (workers scholarships)
- ,
- ,
- ,
- ,
- ,
- , , , ,
- , .
- (America's Learning Exchange, ALX)
- ,
- , (21st Century for
- 21st Century Jobs)
-
- .
- 가 .
- .

- (professional engineer)

-

가 (national organization for competence assurance, NOCA) 가 (American national standards institute, ANSI)

- 가 (national skill standard board, NSSB)

가

가

가 , 가

NSSB 가 가
(national skill standard, NSS) NSS

· 1994 「 가 (national skill standard act)」

NSSB

24

3.

- (global information infrastructure, GII)

· (a framework for global electronic commerce):

가

가

- (the emerging digital economy):
 - 가
- 가 (national information infrastructure, NII) :
 - ,
 - ,
 - /
 - ,
 - ,
- (the technology literacy challenge):
 - ,
 - ,
 - ,
- : , 2000 21
 - ,
 - ,
 - ,
 - 3 6,600
-
-
-
- 가 (national education goal panel):
 - , 10
 - 가
 - 가
 - ,
 - ,
 - ,
- (the office of educational research and improvement, OERI):
 - 가
- (the office of elementary and secondary education):
 - ,
 - ,
 - ,
- (the office of vocational and adult education):
 - ,
 - ,
 - ,

가

가

(occupational safety and health administration, OSHA):

(women's bureau, WB) :

(equal employment opportunity commission):

가 (National Skill Standard Board, NSSB): 가
가

(economic development administration, EDA):

가

가

가

「

」

(core indicator)

, 가 ,

, , 가

, , 19-21 14-18

' 가 (the corporate imperative)'

가

' (school-to-work transition opportunities act)'

'School to Work' 'Work to Work'

가

(ALMIS)

가

NSSB

가

NSS

. NSS

가

21st Century Workforce Commission(2000). A Nation of Opportunity:
Building America's 21st Century Workforce.

(<http://www.workforce21.org/finalreport.htm>)

(2000). ED Strategic Plan and Annual Reports.

(<http://www.ed.gov/pubs/plarpts.html>)

(1997). Departmental Strategic Plan-Overview FY 1997 - FY 2002.

(<http://www.notes.dol.gov/dol/str.../>)

(1998). Message From The Secretary of Labor.

(1999). Futurework: Trends and Challenges for work in the 21st Century.

(<http://www.dol.gov/dol/public/futurework/>)

(1997). Human Resources: Positioning the United States for Scientific
and Technological Leadership and for Workforce Productivity in
the Twenty-First Century.

(<http://www.whitehouse.gov/WH/FOP/OSTP/SNT/chapter6.html>)

(1999). The Emerging Digital Economy .

(<http://www.ecommerce.gov>)

(2000). The Department of Commerce Annual Performance Plan, FY 2000.

- 1 가 ()
- 2 ()
- ()
- 3 (가)
- ()
- 4 ()
- 5 ()
- 6 ()
- 7 ()
- 8 ()
- 9 (가)

E

APEC



ABAC		APEC Business Advisory Council
ACTETSME	APEC	APEC Centre for Technology Exchange & Training for SME
AEMM	APEC	APEC Education Ministerial Meeting
AGGI		Advisory Group on Gender Integration
APEC	.	Asia Pacific Economic Cooperation
APECEF	APEC	APEC Education Foundation
BAC	.	Budget and Administrative Committee
BMC	.	Budget and Management Committee
BMN		Business Management Institute
BVP		Business Volunteer Program
CBN		Capacity Building Network
CTI	.	Committee on Trade & Investment
ECOTECH	.	Economic and Technical Cooperation
EdFor		Education Forum
EDNET		Education Network
FDI		Foreign Direct Investment
HRD		Human Resource Development
HURDIT		Human Resource Development in Industrial Technology
ILO		International Labour Organization
IQAS		International Quality Assurance System
IST		Industrial Science & Technology
JAPET	-APEC .	Japan-APEC Partnership for Education & Training

KDI		Korea Development Institute
LMI		Labour Market Information
LSAC		Lead Shepherd Advisory Committee
LSP	.	Labour & Social Protection Network
MRSQ		Mutual Recognition of Skills Qualification
NEDM		Economic Development Management Network
NGO		Non-Governmental Organization
PECC		Pacific Economic Cooperation Council
PLC		Policy Level Group
PFP		Partners for Progress
SEOM		Senior Education Officials' Meeting
SD	가	Sustainable Development
SME		Small & Medium Enterprise
SOM		Senior Officials Meeting
TILF	.	Trade and Investment Liberalization and Facilitation
TMS		Total Management System
UMAP		University Mobility in Asia Pacific
WG		Working Group
WSLN		Women Senior Leaders' Network

00-

APEC

2000 12

2000 12

2 15- 1 (135- 949)

: [http:// www.krivet.re.kr](http://www.krivet.re.kr)

: (02) 3485- 5000, 5100

: (02) 3485- 5200

16- 1681 (1998. 6. 11)

ISBN 89- 8436- 189- 5 93330

: 02- 3485- 5005, E- mail: jtlee@krivet.re.kr