

02-21-08

 **한국직업능력개발원**

02-21-08

 KRIVET 한국직업능력개발원

.

1. :

2.

가 가 .

3.

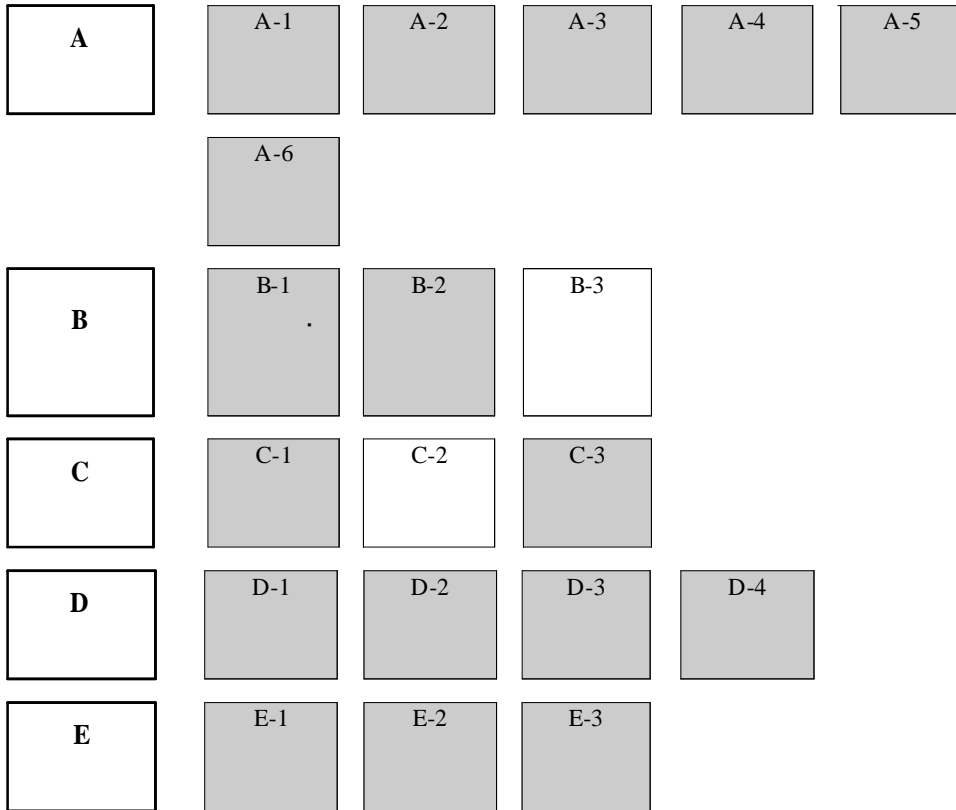

: (Key Task) .

4.

가.					
			K.S.C.O.(No)		
		Character Marketing Planner			
	/			3·4	
	/				
·					
					2
	22				
(OJT)	6		,		
	<p>가</p> <p>,</p> <p>.</p> <p>가</p> <p>,</p> <p>,</p> <p>,</p> <p>,</p> <p>,</p> <p>,</p> <p>,</p> <p>Feed Back</p> <p>,</p> <p>.</p>				

.	
	, ,
	.
.	
	<pre> graph TD A[K.S.C.O.No. 0243] --- B[K.S.C.O.No. 0244] A --- C[K.S.C.O.No. 1832] B --- D[K.S.C.O.No.] C --- D D --- E[K.S.C.O.No. 18324] </pre>
	<p>, ,</p> <p>가</p> <p>,</p> <p>,</p> <p>가 가</p> <p>.</p>

5.

가.					
		가 가			
	No				
A	1		●	●	●
	2		●	●	●
	3		●	●	●
	4		●	●	●
	5		●	●	●
	6		●	●	●
B	1		●	●	●
	2		●	●	●
	3		●	●	●
C	1		●	●	●
	2		●	●	●
	3		●	●	●
D	1		●	●	●
	2		●	●	●
	3		●	●	●
	4		●	●	●
E	1		●	●	●
	2		●	●	●
	3		●	●	●

(KEY TASK)									
	No								
			1	2	3				
A	1		●			●	●	●	
	2			●		●			
	3		●			●	●		
	4		●			●			●
	5		●			●			
	6			●		●		●	
B	1		●			●		●	
	2		●			●		●	
	3				●	●		●	
C	1			●		●	●	●	
	2				●	●	●		
	3			●			●	●	
D	1		●			●	●	●	●
	2		●			●	●	●	●
	3			●		●	●	●	●
	4		●			●	●		●
E	1		●			●	●	●	
	2			●		●	●		●
	3			●		●	●		

.		
[]		
· (PC)	●	
·		●
· PDA		●
·		●
·		●
·	●	
·	●	
·	●	
·	●	
·		●
· CD		●
· LCD		●
[]		
·	●	
·	●	
·	●	
·		●
·	●	
·	●	
·	●	
[]		●
·	●	
·	●	
·	●	
·	●	
()	●	

6.

가.	A-1	
.		
.		
(1) (2) (3) (4)	.	● ● ● ●
	●	
.	(H/ W)	, ,
	(S/ W)	Adobe Illustrator (9.0), Adobe Photoshop (6.0) Quark Express , (2000)

. , (Related Knowledge, Skill & Attitude)		
(Knowledge)	<ul style="list-style-type: none"> • • • 	(1),(2),(3) (1),(2),(3) (1),(2),(3)
(Skill)	<ul style="list-style-type: none"> • • • 	(1),(2),(3) (1),(2),(3) (4)
(Attitude)		•

가.		A-2	
·		·	
·			
(1)			●
(2)			●
(3)			●
(4)			●
(5)			●
		●	
·	(H/ W)	·	
	(S/ W)	(2000)	

. , (Related Knowledge, Skill & Attitude)		
(Knowledge)	<ul style="list-style-type: none"> • • • • 	(1),(2),(3),(4),(5) (1),(2),(3),(4),(5) (1),(2),(3),(4),(5) (1),(2),(4)
(Skill)	<ul style="list-style-type: none"> • • • 	(1),(2),(3),(4),(5) (1),(2),(4) (1),(2),(3),(4),(5)
(Attitude)	<ul style="list-style-type: none"> • 	

가.		A-3	
.			
.			
(1)			●
(2)			●
(3)			●
(4)			●
		●	
.	(H/ W)		
	(S/ W)	2000	

. , (Related Knowledge, Skill & Attitude)		
(Knowledge)	<ul style="list-style-type: none"> • • • • 	(1),(2),(3),(4) (2),(3) (1),(2),(3),(4) (1),(2),(3),(4)
(Skill)	<ul style="list-style-type: none"> • • 	(2),(3) (4)
(Attitude)		

가.	A-4	
.		
.		
(1)	가	●
(2)		●
(3)		●
		●
.	(H/ W)	, ,
	(S/ W)	2000

. , (Related Knowledge, Skill & Attitude)		
(Knowledge)	<ul style="list-style-type: none"> · · · · 	(1),(2),(3) (1),(2),(3) (2),(3) (1),(2),(3)
(Skill)	<ul style="list-style-type: none"> · · · 가 · 	(1),(2),(3) (1),(2) (3) (1),(2),(3)
(Attitude)		

가.	A-5	
.		
.		
(1)		●
(2)		●
		●
.	(H/ W)	, ,
	(S/ W)	Adobe Illustrator 9.0, Adobe Photoshop 6.0 Quark Express 2000

. , (Related Knowledge, Skill & Attitude)		
(Knowledge)	<ul style="list-style-type: none"> • • • • 	(1),(2) (1),(2) (1),(2) (1),(2)
(Skill)	<ul style="list-style-type: none"> • • 	(1),(2) (2)
(Attitude)		

가.	A-6	
.	가	
.		
(1)	.	●
(2)	.	●
(3)	.	●
		●
.	(H/ W)	,
.	(S/ W)	2000

. , (Related Knowledge, Skill & Attitude)		
(Knowledge)	<ul style="list-style-type: none"> • • • 	(1),(3) (1),(2),(3) (1)
(Skill)	<ul style="list-style-type: none"> • • 	(1) (1),(2),(3)
(Attitude)		

(Related Knowledge, Skill & Attitude)		
(Knowledge)	<ul style="list-style-type: none"> • (on-off line) • • • 	(1),(2),(3),(4),(6),(7) (1),(2),(3),(4) (3) (5),(6)
(Skill)	<ul style="list-style-type: none"> • • • • 	(1),(2),(3),(4),(5),(6) (3),(7) (1),(2),(3),(4),(5),(6) (5)
(Attitude)		

가.	B-2		
.			
.			
(1)	가	●	
(2)		●	
(3)		●	
(4)		●	
(5)		●	
(6)		●	
(7)		●	
(8)		●	
(9)		●	
(10)		가	●
(11)			●
(12)		가	●
(13)			●
		●	
.	(H/ W)	, , CD ,	
	(S/ W)	, PPT, Illustrator, Photoshop,	

(Related Knowledge, Skill & Attitude)		
(Knowledge)	<ul style="list-style-type: none"> • • • • • 	<p>(5),(6),(7),(9),(10) (3),(4),(9),(13) (1),(2),(3),(4),(5),(12),(13) (5),(6),(9),(10),(11) (5),(6),(10)</p>
(Skill)	<ul style="list-style-type: none"> • • • • • 	<p>(3),(8),(13) (1),(3),(4),(5),(10),(11),(12),(13) (7),(8),(9),(10),(11),(13) (7),(13) (5),(9),(10),(11)</p>
(Attitude)		

가.		B-3	
.			
.			
(1)		()	●
(2)			●
(3)			●
(4)			●
(5)			●
(6)			●
(7)			●
(8)			●
(9)			●
(10)			●
(11)			●
		●	
.	(H/ W)	,	
	(S/ W)	,	

. , (Related Knowledge, Skill & Attitude)		
(Knowledge)	(1),(4),(5),(6),(7) (4),(5),(6),(7) (2),(3),(9),(11) (1),(4),(5),(6),(7) (2),(3),(9),(11)
(Skill)	. () .	(8) (2),(3),(6),(7),(9),(10)
(Attitude)		

가.		C-1	
.			
.			
(1)	가	●	
(2)	1	●	
(3)	1	●	
(4)		●	
(5)		●	
(6)		●	
(7)		●	
(8)		●	
		●	
.	(H/ W)	, PDA, , , , ,	
	(S/ W)	, ,	

. , (Related Knowledge, Skill & Attitude)		
(Knowledge)	<ul style="list-style-type: none"> · · · · 가 (/) · 가 	(1),(4),(5) (1),(4),(5),(6) (1),(6) (1),(2) (1),(4)
(Skill)	<ul style="list-style-type: none"> · · · 가 · 	(2),(3) (1),(4) (1),(4) (6),(7),(8)
(Attitude)	가 , 가 가 ,	

가.	C-2	
.	, (가 ,) 가 .	
.		
(1)	, 가 , .	●
(2)	가 .	●
(3)	.	●
(4)	()	●
.		
.	(H/ W)	,
.	(S/ W)	,

. , (Related Knowledge, Skill & Attitude)		
(Knowledge)	<ul style="list-style-type: none"> · 가 (/) · 가 	(3),(4) (1),(2) (1),(2) (1),(2) (1),(2) (1),(2) (1),(2)
(Skill)	<ul style="list-style-type: none"> · 가 () · () · · 	(1),(2) (1),(2) (1),(2) (3),(4)
(Attitude)	가 가 , 가 가 .	

가.	C-3	
.	가 가	
.		
(1)	가	●
(2)		●
(3)		●
(4)		●
(5)		●
(6)		●
(7)		●
(8)		●
		●
.	(H/ W)	,
.	(S/ W)	,

· , (Related Knowledge, Skill & Attitude)		
(Knowledge)	· · · · , ·	(1),(7) (2),(5) (2),(3) (2),(3),(4),(6) (4), (6)
(Skill)	· (,) · · · · ()	(2),(7),(8) (2) (3),(4),(5) (4) (6)
(Attitude)	·	가

가.	D-1	
.	가	
.		
(1)	POP	●
(2)		●
(3)		●
(4)		●
(5)		●
(6)		●
(7)		●
(8)		●
(9)		●
		●
.	(H/W)	, , (G3/ G4), PC(,),
.	(S/W)	Adobe Illustrator 9.0, Adobe Photoshop 6.0 Quark Express 2000 Adobe Illustrator R8,9,10 / Adobe Photoshop R6,7 / Corel Draw R9,10 / Page Maker R6,7 / Quark X press R3.3, 4

. , (Related Knowledge, Skill & Attitude)		
(Knowledge)	<ul style="list-style-type: none"> · · · · 	(1),(2),(3),(4),(5),(6),(7),(8),(9) (1),(2),(3),(4),(5),(6),(7),(8),(9) (1),(2),(3),(4),(5),(6),(7),(8),(9) (3),(4),(5),(6),(7),(8),(9)
(Skill)	<ul style="list-style-type: none"> · · · POP · · · · · 	(1),(2) (3) (4) (5) (6) (7) (8) (9)
(Attitude)	<ul style="list-style-type: none"> · 	

가.	D-2	
.		
.		
(1) (2) (3) (4) (5) (6) (7) (8) (9)	, (),	● ● ● ● ● ● ● ● ●
	●	
.	(H/ W)	, , , , TV, , , (G3/ G4), PC(,), ,
	(S/ W)	2000 Adobe Illustrator R8,9,10 / Adobe Photoshop R6,7 / Corel Draw R9,10 / Page Maker R6,7 / Quark X press R3.3, 4

. , (Related Knowledge, Skill & Attitude)		
(Knowledge)	. . .	(1),(2),(3),(4),(5),(6),(7),(8),(9) (1),(2),(3),(4),(5),(6),(7),(8),(9) (1),(2),(3),(4),(5),(6),(7),(8),(9)
(Skill)	(1),(2),(3),(4),(5),(6),(7),(8),(9) (2) (4),(5),(6),(7),(8),(9) (3)
(Attitude)	.	

가.	D-3	
.	.	
.		
(1)	.	●
(2)	.	●
(3)	.	●
(4)	.	●
(5)	.	●
(6)	.	●
(7)	.	●
(8)	.	●
(9)	.	●
	●	
.	(H/ W)	, , , TV, (G3, G4), PC(,), , ,
.	(S/ W)	Adobe Illustrator 9.0, Adobe Photoshop 6.0, Quark Express 2000, Adobe Illustrator R8,9,10 / Adobe Photoshop R6,7 / Corel

. , (Related Knowledge, Skill & Attitude)		
(Knowledge)	<ul style="list-style-type: none"> · · · · 	(1),(2),(3),(4),(5),(6),(7),(8),(9) (1),(2),(3),(5),(6),(7),(8),(10) (1),(2),(3),(5),(6),(7),(8),(9),(10) (1),(2),(3),(4),(5),(6),(7),(8),(9)
(Skill)	<ul style="list-style-type: none"> · · · · · 	(1),(2),(3),(5),(6),(7),(8) (3),(5),(6),(7),(8) (4) (8) (9)
(Attitude)		·

<p style="text-align: center;">. , (Related Knowledge, Skill & Attitude)</p>		
(Knowledge)	<ul style="list-style-type: none"> · · · 	<p>(1),(2),(3),(4),(5),(6),(7),(8),(9),(10),(11),(12),(13)</p> <p>(1),(2),(3),(4),(5),(6),(7),(8),(9),(10),(11),(12),(13)</p> <p>(1),(2),(3),(4),(5),(6),(7),(8),(9),(10),(11),(12),(13)</p>
(Skill)	<ul style="list-style-type: none"> · · · 	<p>(1),(2),(3),(4),(5),(6),(7),(8),(9),(10),(11),(12)</p> <p>(2),(3),(4),(5),(6),(7),(8),(9),(10),(11),(12),(13)</p> <p>(13)</p>
(Attitude)	<p style="text-align: center;">.</p>	<p>가</p>

가.	E-1	
.	가 , (가 ,)	
.		
(1)	가	●
(2)		●
(3)		●
(4)		1 ●
(5)		1 ●
(6)		●
(7)		●
(8)		●
(9)		●
		●
.	(H/ W)	, , PDA, ,
	(S/ W)	, ,

<p style="text-align: center;">. , (Related Knowledge, Skill & Attitude)</p>		
(Knowledge)	<ul style="list-style-type: none"> · · · 	<p>(1),(2),(3),(4),(5),(6),(7),(8),(9)</p> <p>(2),(3),(4),(7)</p> <p>(2),(3),(4),(5),(7),(8),(9)</p>
(Skill)	<ul style="list-style-type: none"> · · · (가 ,) · · · · 가 	<p>(1),(2),(3),(4),(5),(6),(9)</p> <p>(1),(2)</p> <p>(2),(4)</p> <p>(8)</p> <p>(1),(4)</p> <p>(5)</p> <p>(6)</p>
(Attitude)	<p style="text-align: center;">. , , 1</p>	

가.	E-2	
.	.	
.		
(1) (2) (3) (4) (5) (6) (7) , , . .	● ● ● ● ● ● ●
	●	
.	(H/ W) ,	
	(S/ W)	, , ,

· , (Related Knowledge, Skill & Attitude)		
(Knowledge)	· ·	(2),(3),(4),(6),(7) (2),(3),(4),(6),(7)
(Skill)	· · · (, , ,) ·	(1),(5) (2),(3),(4),(6),(7) (2),(3),(4),(6) (7)
(Attitude)	,	가

가.		E-3	
·		,	
·			
(1)			●
(2)			●
(3)			●
(4)			●
(5)			●
(6)			●
(7)			●
(8)			●
(9)			●
		●	
·	(H/ W)	,	
	(S/ W)	,	

. , (Related Knowledge, Skill & Attitude)		
(Knowledge)	<ul style="list-style-type: none"> • • 	(5) (1)
(Skill)	<ul style="list-style-type: none"> • • • • • 	(2),(3) (4) (5) (6),(7),(8) (9)
(Attitude)		

. / . .

1. / . .

가. /

	1	2	3	4	5	6	7	8	9	10	11			
A-1			●			●								
A-2			●		●	●					●			
A-3			●		●	●					●			
A-4			●		●	●					●			
A-5			●		●	●					●			
A-6			●		●	●					●			
B-1			●			●		●		●				
B-2			●			●		●		●				
B-3						●		●						
C-1						●		●						
C-2						●		●						
C-3						●		●						
D-1	●	●		●		●								
D-2	●	●		●		●								
D-3	●	●		●		●								
D-4	●	●		●		●								
E-1	●					●	●				●			
E-2					●	●	●				●			
E-3			●		●	●	●		●	●	●			

. /

	1	2	3	4	5	6	7	8						
A-1		●												
A-2	●	●												
A-3	●	●												
A-4		●												
A-5	●	●												
A-6		●												
B-1		●						●						
B-2		●					●	●						
B-3		●						●						
C-1		●												
C-2		●												
C-3		●												
D-1		●	●	●	●									
D-2		●	●	●	●									
D-3		●	●	●	●									
D-4		●	●	●	●									
E-1		●												
E-2		●												
E-3		●				●								

. /

	1	2	3	4	5	6	7	8	9	10			
A-1	●	●	●	●			●	●	●	●			
A-2	●	●	●	●			●	●	●	●			
A-3	●	●	●	●		●	●	●	●	●			
A-4	●	●	●	●		●	●	●	●	●			
A-5	●	●	●	●		●	●	●	●	●			
A-6	●	●	●	●			●	●	●	●			
B-1	●	●	●	●	●	●		●	●	●			
B-2	●	●	●	●	●	●	●	●	●	●			
B-3	●	●	●	●			●			●			
C-1	●	●	●	●			●			●			
C-2	●	●	●	●			●			●			
C-3	●	●	●	●			●			●			
D-1	●	●	●	●		●	●	●	●	●			
D-2	●	●	●	●		●	●	●	●	●			
D-3	●	●	●	●		●	●	●	●	●			
D-4	●	●	●	●		●	●	●	●	●			
E-1	●	●	●	●			●	●	●	●			
E-2	●	●	●	●					●	●			
E-3	●	●	●	●			●	●	●	●			

2. /

	1	2	3	4					
A-1	●	●	●						
A-2	●	●	●						
A-3	●	●	●						
A-4	●	●	●						
A-5	●	●	●						
A-6		●							
B-1		●							
B-2		●							
B-3		●							
C-1			●						
C-2			●						
C-3			●						
D-1				●					
D-2				●					
D-3				●					
D-4				●					
E-1	●		●	●					
E-2			●	●					
E-3	●	●	●	●					

1.

:			
:			
		()	
1.		[: 42]	
2.		16	●
		24	●
	PC,		
()			

:			
:			
	, PR		
		()	
1.		[: 145] 35	●
2.		45	●
3.		20	●
4.		45	●
	PC, , OHP, VTR		
	,		
	,		
()	(,)		

:			
:			
		()	
		[: 120]	
1.	(, 가 , ,)	50	●
2.		35	●
3.		35	●
	PC,		
	, ,		
	, ,		
()	(, , ,), (, , ,)		

:			
:			
	.		
		()	
1.		[: 144] 51	●
2.		39	●
3.		54	●
	PC, , OHP, VTR		
	,		
	,		
()	(, ,), (, ,)		

2.

:		
:		
	가	
		[: 16]
1.	가. · · , ,	2
2.	가. ·	2
3.	가. · ·	6
4.	가. · ,	4
5.	가. · ,	2
	, , ,	
	,	
()	-	

:		
:		
	.	
		[: 24]
1.	가. .	4
2.	가. .	6
3.	가. .	4
4.	가. .	4
5.	가. . .	6
	PC,	
()		

:		
:		
	가	가 .
		[: 35]
1.	가.	1
2.	가. .	12
3.	가. .	8
4.	가. .	7
5.	가. . 가	7
	, , ,	
	,	
()		

:			
:			
	,		
			[: 45]
1.	가.		9
	·		
	·		
2.	가.	/	9
	·		
	·		
3.	가.		9
	·		
	·		
4.	가.		9
	·		
	·		
5.	가.		9
	·		
	·		
	PC, , OHP, VTR		
	,		
()	,		

:		
:		
	, 가 .	
		[: 20]
1.	가. . .	4
2.	가. . .	4
3.	가. . .	8
4.	가. . PR	2
5.	가. . .	2
	, , ,	
	,	
()	, ,	

:		
:		
	, .	
		[: 45]
1.	가. .	9
2.	가. .	9
3.	가. .	9
4.	가. .	9
5.	가. .	9
	PC, , OHP, VTR	
	,	
()	, , ,	

:		
:		
		[: 50]
1.	가. · ·	10
2. 가	가. 가 · 가 · 가	15
3.	가. 가 · / ·	15
4.	가. () ·	10
	, ,	
()	,	

:		
:		
	.	
		[: 35]
1.	가. .	9
2.	가. ./	9
3.	가. .	9
4. ()	가. () .	8
	,	
()	,	

:		
:		
	.	
		[: 35]
1.	가. . .	5
2.	가. , , . .	8
3.	가. / . .	8
4.	가. . .	8
5.	가. . .	6
	,	
()	, , ,	

:		
:		
	가	
		[: 51]
1.	가. .	9
2.	가. .	9
3.	가. . . TV, (,) .	15
4.	가. P.O.P .	6
5.	가. () .	12
	PC,	
	,	
()	, ,	

:		
:		
	가 가 .	
		[: 39]
1.	가. · ·	9
2. :	가. · ·	9
3. :	가. · ·	9
4.	가. · · , , ·	12
	PC,	
()	, , ,	

:		
:		
	가	.
		[: 54]
1.	가. .	12
2.	가. .	9
3.	가. .	9
4.	가.	24
	,	
	,	
()	, , , ,	

3.

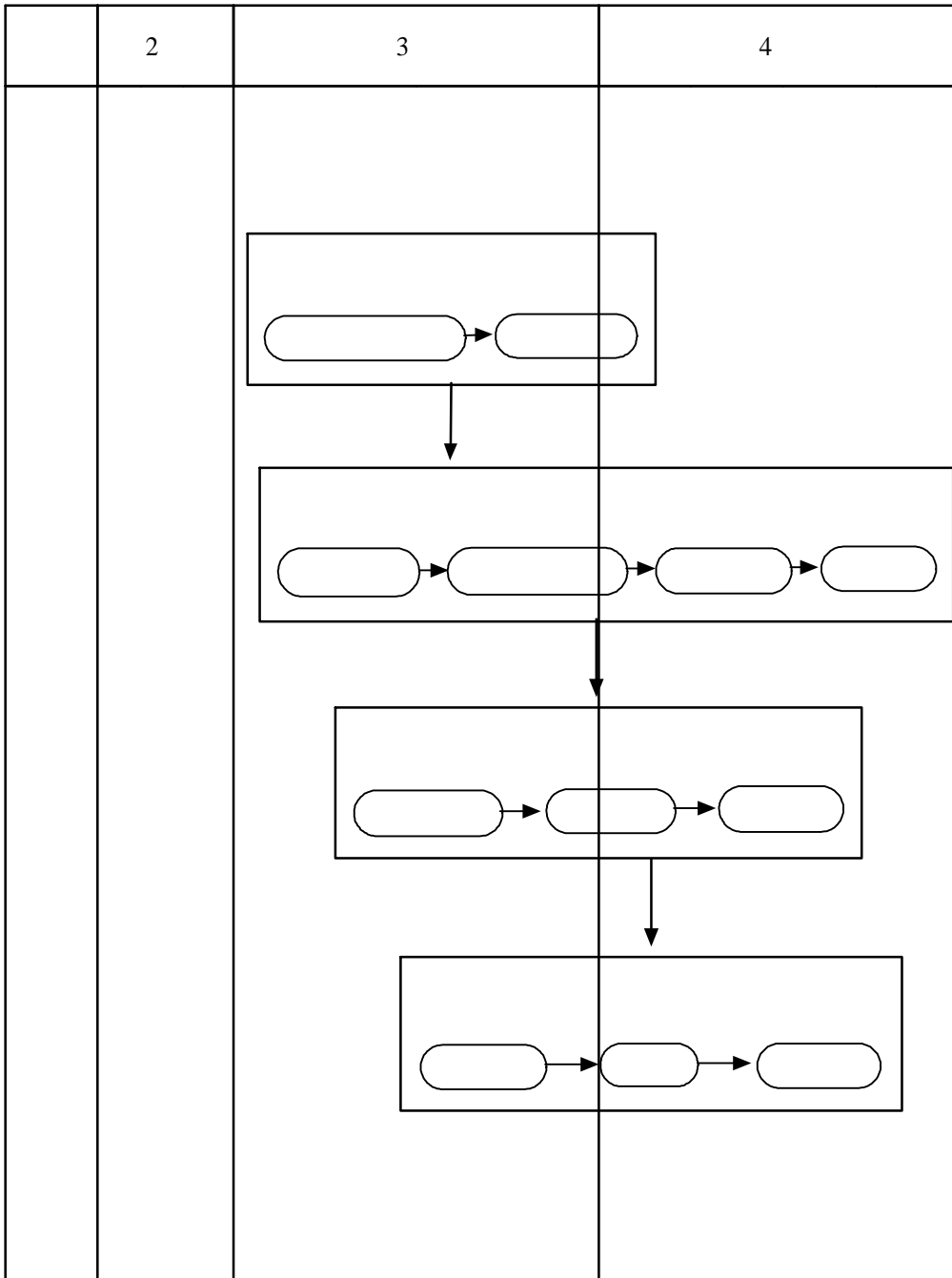

	<p style="text-align: right;">가</p> <p>4가</p> <p>가</p>
--	--

		1 · 2	
		2	가 .
		1	가 .
		()	
		1. 1 (60%) 2 (50%)	가. . . .
		2. 1 (50%) 2 (40%)	가. . . .
		3. 1 (60%) 2 (50%)	가. . . .
		4. 1 (50%) 2 (40%)	가. . . .
		2	(5)
		1	
		, , ,	

		1 . 2	
		2	, 가 .
		1	, 가 .
		()	
		1.	가. . 가 가 . 가 . . 가. . . 가. . . 가. . . QC
		2. 가. . . 가. . . QC
		3. 가. . . 가. . . QC
		1	,
		2	
		, , , ,	

		1 . 2	
		2	가 .
		1	() 가 .
		()	
		1.	가.
		1 (20%)	.
		2 (20%)	.
		2.	가.
		1 (40%)	.
		2 (40%)	.
		3.	가. ()
		1 (20%)	.
		4.	가.
		1 (20%)	. TV, (,
		2 (40%))
			.
		2	
		1	, (:)
			, , ,

		1 . 2		
		2	가 .	
		1	가 .	
		()		
1	1.	1 (30%) 2 (35%)	가. ·	● ● ● ●
	2.	1 (30%) 2 (35%)	가. ·	● ● ● ●
	3.	1 (40%) 2 (30%)	가. · ·	● ● ● ● ● ●
	2	,		
	1			
		,		

		1 · 2	
		2	가 .
		1	가 .
		()	
		1.	가.
		1 (60%)	.
		2 (50%)	.
		2.	가.
		1 (50%)	.
		2 (40%)	.
		3.	가.
		1 (60%)	.
		2 (50%)	.
		4.	가.
		1 (50%)	.
		2 (40%)	.
		2	,
		1	, ,
		2	(5)
		1	
		, , ,	

		1 . 2	
		2	. , 가 .
		1	. , 가
		()	
		1.	가. . 가 . .
		2.	가. . .
		3.	가. . .
			● ● ● ● ● ● ● ● ● ● ● ● ● ● ● ●
		1	
		2	
		1	,
		2	
		, , , ,	

		1 . 2	
		2	가 .
		1	가 .
		()	
		1.	가.
		1 (20%)	.
		2 (20%)	.
		2.	가.
		: .	.
		1 (10%)	.
		2 (10%)	.
		3.	가.
		1 (20%)	.
		2 (30%)	. , ,
			.
		4.	가.
		1 (20%)	.
		2 (20%)	.
		5.	가.
		1 (30%)	.
		2 (20%)	.
		2	
		1	
		2	
		1	
		, ,	

		1 . 2	
		2	가 .
		1	가 .
		()	
		1. 1 (40%) 2 (60%) 2. 1 (50%) 2 (50%) 3. 1 (60%) 2 (40%)	가. · 가. · () · 가. · · ·
	2	,	
	1	,	
	2	,	
	1		
		,	

2.

		1998	98 - 6 - 01
		1998	98 - 6 - 02
		1998	98 - 6 - 03
		1998	98 - 6 - 04
	가	1998	98 - 6 - 05
		1998	98 - 6 - 06
		1999	99 - 9 - 01
		2000	00 - 15 - 01
	가	2002	02 - 21- 01
		2002	02 - 21- 02
		2002	02 - 21- 03
		2002	02 - 21- 04
		2002	02 - 21- 05
		2002	02 - 21- 06
		2002	02 - 21- 07
		2002	02 - 21- 08
	가	2002	02 - 21- 09
		2002	02 - 21- 10
		1998	98 - 6 - 07
		1999	99 - 9 - 02
		1999	99 - 9 - 03
		2000	00 - 18 - 02
		2000	00 - 16 - 03
		2000	00 - 17 - 04
		2000	00 - 19 - 05
		1998	98 - 6 - 08
		1998	98 - 6 - 09
		1998	98 - 6 - 10
		1999	99 - 9 - 04
		1999	99 - 9 - 05
		1999	99 - 9 - 06
		1999	99 - 9 - 07
		1999	99 - 9 - 08
		2000	00 - 21- 06
		2000	00 - 20 - 07
		2000	00 - 22 - 08
	가	2001	01 - - 01
		2001	01 - - 02
	CRM 가	2001	01 - - 03
	가(CE)	2001	01 - - 04
		2001	01 - - 05
		2001	01 - - 06
	PD	2001	01 - - 07
		2001	01 - - 08
		2001	01 - - 09
		2001	01 - - 10
		2000	00 - 23 - 09

		1998	98 - 6 - 11
		1998	98 - 6 - 12
		1998	98 - 6 - 13
		1998	98 - 6 - 14
	.	1999	99 - 9 - 09
		1999	98 - 6 - 15
		1999	98 - 6 - 16
		2000	00 - 24 - 10
		2000	00 - 25 - 11
		2000	00 - 26 - 12
		1998	98 - 6 - 17
		1998	98 - 6 - 18
		1998	98 - 6 - 19
		1998	98 - 6 - 20
		1999	99 - 9 - 10
		2000	00 - 27 - 13
		1999	99 - 9 - 11
		1999	99 - 9 - 12



(<http://www.krivet.re.kr> → 가 → KRIVET DB →)

()
()
()
()
()
()

02-21-08

2002	12
2002	12

2 15-1 (135-949)

: [http:// www.krivet.re.kr](http://www.krivet.re.kr)

: (02) 3485-5000, 5100

: (02) 3485-5200

16-1681 (1998. 6. 11)

ISBN 89-8436-538-6 94330

89-8436-529-7 (11)

○ ○

4,000



: (02)3485-5122 E-mail : yhpark@krivet.re.kr